

# INSTRUCTION MANUAL

AC/DC 315 Razor Digital  
AC/DC Inverter TIG/ARC Welder (415V)  
10-315A #KUMJRRW315ACDC



W175

# UNIMIG

## OPERATING MANUAL

### KUMJRRW315AC/DC



**3 YEARS Warranty**  
(Power Source)

Please read and understand this instruction manual carefully before the installation and operation of this equipment.

## **Thank you for your purchase of your UNIMIG TIG Welding Machine.**

We are proud of our range of welding equipment that has a proven track record of innovation, performance and reliability. Our product range represents the latest developments in Inverter technology put together by our professional team of highly skilled engineers. The expertise gained from our long involvement with inverter technology has proven to be invaluable towards the evolution and future development of our equipment range. This experience gives us the inside knowledge on what the arc

characteristics, performance and interface between man and machine should be. Within our team are specialist welders that have a proven history of welding knowledge and expertise, giving vital input towards ensuring that our machines deliver control and performance to the utmost professional level.

We employ an expert team of professional sales, marketing and technical personnel that provide us with market trends, market feedback and customer comments and requirements. Secondly they provide a customer support service that is second to none, thus ensuring our customers have confidence that they will be well satisfied both now and in the future.

UNIMIG welders and plasma cutters are manufactured to be compliant with - AS/NZ 60974-1, guaranteeing you electrical safety and performance.

## **WARRANTY**

- 3 Years from date of purchase.
- Welding Guns of Australia Pty Ltd Ltd warranties all goods as specified by the manufacturer of those goods.
- This Warranty does not cover freight or goods that have been interfered with.
- All goods in question must be repaired by an authorised repair agent as appointed by this company.
- Warranty does not cover abuse, mis-use, accident, theft, general wear and tear.
- New product will not be supplied unless Welding Guns of Australia Pty Ltd has inspected product returned for warranty and agree's to replace product.
- Product will only be replaced if repair is not possible
- Please view full Warranty term and conditions supplied with machine or at [www.unimig.com.au/warranty.asp](http://www.unimig.com.au/warranty.asp) or at the back of this manual.

<b>CONTENTS</b>	<b>PAGE</b>
<b>Warranty</b>	2
<b>Safety - Cautions</b>	4-6
<b>Technical Data, Product Information</b>	7
<b>Machine Layout Description</b>	8
<b>Front Panel Operation - Weld Program Controller</b>	9
■ Mode Select	9
■ Adjustment Encoder Knob	10
■ Voltage Display Select	10
■ Torch Cycle Select	10
■ Job Recall Select	10
<b>Weld Program Selection &amp; Setting</b>	11
■ Pre-gas	11
■ Start Current	11
■ Upslope	11
■ Base Current	12
■ Peak Current	12
■ Down Slope	12
■ Finish Current	12
■ Post Gas	13
<b>Pulse Mode Selection &amp; Setting</b>	13
■ Pulse Frequency Hz	13
■ Pulse % Width	13
<b>AC Wave Selection &amp; Setting</b>	
■ AC Wave Frequency Hz	13
■ AC Wave Balance	14
<b>MMA (Stick Electrode) Selection &amp; Setting</b>	14
■ Ignition Current	14
■ Ignition Time	14
■ Weld Current	15
■ Arc Force	15
<b>LED Display Functions &amp; Alarm LED Codes</b>	16-17
<b>Weld Settings Storage - Job Recall</b>	17
<b>MMA (Stick) Welding - Setup &amp; Operation</b>	18-19
■ MMA (Stick) Welding Fundamentals	20-21
<b>DC HF TIG Welding - Setup &amp; Operation</b>	23
■ DC TIG Welding Fundamentals	24
■ TIG Welding Fusion & Filler Wire Technique	25
■ Pulse TIG Welding Fundamentals	26
<b>DC PULSE TIG Welding - Setup &amp; Operation</b>	27
<b>AC TIG Welding - Setup &amp; Operation</b>	28-29
■ AC Wave Form Fundamentals	30-31
<b>AC PULSE TIG Welding - Setup &amp; Operation</b>	32-33
■ AC Wave Balance Control	34
<b>Remote Amperage Controls</b>	35
<b>Tungsten Electrodes</b>	36-37
<b>XA26 TIG Torch Parts List Breakdown</b>	38-39
<b>Trouble Shooting Guide - TIG Welding</b>	40-41
<b>Trouble Shooting Guide - MMA (Stick) Welding</b>	42



# SAFETY

Welding and cutting equipment can be dangerous to both the operator and people in or near the surrounding working area, if the equipment is not correctly operated. Equipment must only be used under the strict and comprehensive observance of all relevant safety regulations. Read and understand this instruction manual carefully before the installation and operation of this equipment.

## Machine Operating Safety

- Do not switch the function modes while the machine is operating. Switching of the function modes during welding can damage the machine. Damage caused in this manner will not be covered under warranty.
- Disconnect the electrode-holder cable from the machine before switching on the machine, to avoid arcing should the electrode be in contact with the work piece.
- Operators should be trained and or qualified.



**Electric shock: It can kill.** Touching live electrical parts can cause fatal shocks or severe burns. The electrode and work circuit is electrically live whenever the output is on. The input power circuit and internal machine circuits are also live when power is on. In Mig/Mag welding, the wire, drive rollers, wire feed housing, and all metal parts touching the welding wire are electrically live. Incorrectly installed or improperly grounded equipment is dangerous.

- Connect the primary input cable according to Australian and New Zealand standards and regulations.
- Avoid all contact with live electrical parts of the welding circuit, electrodes and wires with bare hands. The operator must wear dry welding gloves while he/she performs the welding task.
- The operator should keep the work piece insulated from himself/herself.
- Keep cords dry, free of oil and grease, and protected from hot metal and sparks.
- Frequently inspect input power cable for wear and tear, replace the cable immediately if damaged, bare wiring is dangerous and can kill.
- Do not use damaged, under sized, or badly joined cables.
- Do not drape cables over your body.
- We recommend (RCD) safety switch is used with this equipment to detect any leakage of current to earth.



**Fumes and gases are dangerous.** Smoke and gas generated whilst welding or cutting can be harmful to people's health. Welding produces fumes and gases. Breathing these fumes and gases can be hazardous to your health.

- Do not breathe the smoke and gas generated whilst welding or cutting, keep your head out of the fumes
- Keep the working area well ventilated, use fume extraction or ventilation to remove welding fumes and gases.
- In confined or heavy fume environments always wear an approved air-supplied respirator. Welding fumes and gases can displace air and lower the oxygen level causing injury or death. Be sure the breathing air is safe.
- Do not weld in locations near de-greasing, cleaning, or spraying operations. The heat and rays of the arc can react with vapours to form highly toxic and irritating gases.
- Materials such as galvanized, lead, or cadmium plated steel, containing elements that can give off toxic fumes when welded. Do not weld these materials unless the area is very well ventilated, and or wearing an air supplied respirator.



**Arc rays: harmful to people's eyes and skin.** Arc rays from the welding process produce intense visible and invisible ultraviolet and infrared rays that can burn eyes and skin.

- Always wear a welding helmet with correct shade of filter lens and suitable protective clothing including welding gloves whilst the welding operation is performed.
- Measures should be taken to protect people in or near the surrounding working area. Use protective screens or barriers to protect others from flash, glare and sparks; warn others not to watch the arc.



**Fire hazard.** Welding on closed containers, such as tanks, drums, or pipes, can cause them to explode. Flying sparks from the welding arc, hot work piece, and hot equipment can cause fires and burns. Accidental contact of electrode to metal objects can cause sparks, explosion, overheating, or fire. Check and be sure the area is safe before doing any welding.

- The welding sparks & spatter may cause fire, therefore remove any flammable materials well away from the working area. Cover flammable materials and containers with approved covers if unable to be moved from the welding area..
- Do not weld on closed containers such as tanks, drums, or pipes, unless they are properly prepared according to the required Safety Standards to insure that flammable or toxic vapors and substances are totally removed, these can cause an explosion even though the vessel has been “cleaned”. Vent hollow castings or containers before heating, cutting or welding. They may explode.
- Do not weld where the atmosphere may contain flammable dust, gas, or liquid vapours (such as petrol)
- Have a fire extinguisher nearby and know how to use it. Be alert that welding sparks and hot materials from welding can easily go through small cracks and openings to adjacent areas. Be aware that welding on a ceiling, floor, bulkhead, or partition can cause fire on the hidden side.



**Gas Cylinders.** Shielding gas cylinders contain gas under high pressure. If damaged, a cylinder can explode. Because gas cylinders are normally part of the welding process, be sure to treat them carefully. CYLINDERS can explode if damaged.

- Protect gas cylinders from excessive heat, mechanical shocks, physical damage, slag, open flames, sparks, and arcs.
- Insure cylinders are held secure and upright to prevent tipping or falling over.
- Never allow the welding electrode or earth clamp to touch the gas cylinder, do not drape welding cables over the cylinder.
- Never weld on a pressurised gas cylinder, it will explode and kill you.
- Open the cylinder valve slowly and turn your face away from the cylinder outlet valve and gas regulator.



**Gas build up.** The build up of gas can causes a toxic environment, deplete the oxygen content in the air resulting in death or injury. Many gases use in welding are invisible and odourless.

- Shut off shielding gas supply when not in use.
- Always ventilate confined spaces or use approved air-supplied respirator.

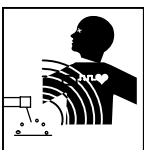

**Electronic magnetic fields.** MAGNETIC FIELDS can affect Implanted Medical Devices.

- Wearers of Pacemakers and other Implanted Medical Devices should keep away.
- Implanted Medical Device wearers should consult their doctor and the device manufacturer before going near any electric welding, cutting or heating operation.



**Noise can damage hearing.** Noise from some processes or equipment can damage hearing. Wear approved ear protection if noise level is high.



**Hot parts.** Items being welded generate and hold high heat and can cause severe burns. Do not touch hot parts with bare hands. Allow a cooling period before working on the welding gun. Use insulated welding gloves and clothing to handle hot parts and prevent burns.

# CAUTION

## 1. Working Environment.

- 1.1 The environment in which this welding equipment is installed must be free of grinding dust, corrosive chemicals, flammable gas or materials etc, and at no more than maximum of 80% humidity.
- 1.2 When using the machine outdoors protect the machine from direct sun light, rain water and snow etc; the temperature of working environment should be maintained within -10°C to +40°C.
- 1.3 Keep this equipment 30cm distant from the wall.
- 1.4 Ensure the working environment is well ventilated.

## 2. Safety Tips.

### 2.1 Ventilation

This equipment is small-sized, compact in structure, and of excellent performance in amperage output. The fan is used to dissipate heat generated by this equipment during the welding operation.

**Important:** Maintain good ventilation of the louvers of this equipment. The minimum distance between this equipment and any other objects in or near the working area should be 30 cm. Good ventilation is of critical importance for the normal performance and service life of this equipment.

### 2.2 Thermal Overload protection.

Should the machine be used to an excessive level, or in high temperature environment, poorly ventilated area or if the fan malfunctions the Thermal Overload Switch will be activated and the machine will cease to operate. Under this circumstance, leave the machine switched on to keep the built-in fan working to bring down the temperature inside the equipment. The machine will be ready for use again when the internal temperature reaches safe level.

### 2.3 Over-Voltage Supply

Regarding the power supply voltage range of the machine, please refer to “Main parameter” table. This equipment is of automatic voltage compensation, which enables the maintaining of the voltage range within the given range. In case that the voltage of input power supply amperage exceeds the stipulated value, it is possible to cause damage to the components of this equipment. Please ensure your primary power supply is correct.

- 2.4 Do not come into contact with the output terminals while the machine is in operation. An electric shock may possibly occur.

# MAINTENANCE

Exposure to extremely dusty, damp, or corrosive air is damaging to the welding machine. In order to prevent any possible failure or fault of this welding equipment, clean the dust at regular intervals with clean and dry compressed air of required pressure.

**Please note that:** lack of maintenance can result in the cancellation of the guarantee; the guarantee of this welding equipment will be void if the machine has been modified, attempt to take apart the machine or open the factory-made sealing of the machine without the consent of an authorized representative of the manufacturer.

# TROUBLE SHOOTING

Caution: Only qualified technicians are authorized to undertake the repair of this welding equipment.

For your safety and to avoid Electrical Shock, please observe all safety notes and precautions detailed in this manual.

## Note:

Minimum Motor Generator Power Suggested: 7KVA

- Our equipment as described in this manual conforms to all applicable rules and regulations of the ‘LowVoltage Directive’ (European Council Directive 73/23/EEC) as set out and amended by Council Directive 93/68/EEC) and to the National legislation for the enforcement of this Directive.
- Our equipment as described in this manual conforms to all applicable rules and regulations of the European Council Directive 89/336/EEC, (EMC Directive) and to the National legislation for the enforcement of this Directive.

# RAZOR DIGITAL 315 AC/DC TIG/MMA - Digital Inverter Welder



**Razorweld**

**Welds:** Aluminium, Magnesium, Zinc Alloys, Steels, Stainless,  
Cast Iron, Bronze, Copper

- Latest IGBT Inverter Technology
- AC/DC HF TIG/MMA Function
- 2T/4T 2S/4S Trigger Select
- AC Square Wave • AC Balance Control
- Pulse Control
- Pulse Width Control • Base CurrentControl
- Up Slope / Down Slope Control
- Pre Gas / Post Gas Control
- Arc Ignition Current Control
- Arc Ignition Time Set Control
- Arc Force Select
- Remote Amperage Control
- Job Memory / Recall

## Technical Data

Power Supply / Phases (V-Ph)	415V - 3 ±15%
Rated input capacity (KVA)	9
Rated Input Power (KW)	8.4
ieff (Amps)	13
imax (Amps)	19
Rated Output (A/V)	315/22.6 TIG 250/30 MMA
No-Load Voltage (V)	45
Duty Cycle @ 40°C as per AS/NZ60974-1	20%@315Amps TIG 60%@230Amps MMA
Power Factor	0.93
Protection Class	IP21S
Insulation Class	B
Cooling Mode	Forced air cooling

### Parameters in MMA (DC, AC)

Welding current range (A)	DC: 10~250 / AC 20~250
Arc ignition range (A)	DC: 10~300 / AC 20~300
Arc force current range (A)	0~100
AC frequency (Hz)	50

### Parameters in TIG (DC, DC pulsed, AC, AC pulsed)

Start current range (A)	DC: 10~320 / AC: 20~250
Peak current range (A)	DC: 10~320 / AC: 20~320
Base current range (A)	DC: 10~320 / AC: 30~320
Finish current range	DC: 10~320 / AC: 20~250
DC pulse frequency range (Hz)	0.5~200
DC pulse duty (%)	10~90
AC frequency range (Hz)	20~70
AC balance	10~60
AC pulse frequency range (Hz)	0.5~5.0
AC pulse duty (%)	10~90
Upslope time (s)	0~60
Downslope time (s)	0~60
Pre-flow time (s)	0~15.0
Post-flow time (s)	2.0~20.0
Arc ignition mode	Contact arc ignition, HF arc ignition
Size (mm)	590x375x380
Weight (kg)	33Kg
Warranty	3 years on power source
Certification Approval	AS/NZ60974-1



UTJRFC-3  
Remote Foot Control Option

UTJRTROLLEY  
Trolley Option

## Overview

The RAZOR315AC/DC is a Digital Controlled square wave AC/DC TIG inverter welder with full TIG functionality that offers simple step by step digital setting of functions and parameters providing you with complete professional control. HF arc ignition provides pre gas with instant arc ignition leaving no tungsten inclusion or contamination of the tungsten electrode. Digital set of Pre Gas Time, Start Current, Up Slope and Down Slope Time, Finish Current Level and Post Gas Time with the choice of 2T or 4T trigger function allows controlling the start and finish of the weld process at a professional level. Digital Pulse Frequency Control gives full parameter setting of Peak Current, Base Current, Pulse Frequency and Pulse Width, allowing control of heat input into the work for penetration control and minimising distortion. AC Square Wave with Balance Control gives maximum control of the electron flow at the tungsten allowing to set the AC TIG arc for maximised cleaning of the oxide layer on aluminium for a deeper penetrating weld. Combined functions of the RAZOR315AC/DC ensures comprehensive control of welding parameters when welding AC and DC weldable materials to produce high quality Tig welds. Our unique Torch Remote Control Interface provides remote amperage control from the torch in both static and live welding modes. The DC MMA welding function delivers a smooth and stable arc allowing easy welding with electrodes obtaining high quality welds including cast Iron, stainless and low hydrogen. The added bonus of Arc Ignition and Arc Force control allows you to set the ideal arc condition no matter what electrode you choose. The RAZOR315AC/DC has raised the benchmark for 415V three phase AC/DC welders making it ideal for multiple applications; aluminium & stainless steel fabrication and repair and maintenance applications. Built to our specification and manufactured in compliance to AS/NZ60974-1.

## MACHINE PACKAGE: KUMJRRW315AC/DC

Standard option includes: RAZOR315AC/DC Machine, SR26 TIG Torch x 4m, Earth Lead & Arc Lead 25mm x 4m, UNI-FLAME Argon Regulator, 2M Gas Hose with fittings



Front Machine Layout Description



- 1. Control panel
- 2. Negative output socket
- 3. Torch gas connector outlet
- 4. Torch Switch Connector
- 5. Remote Foot Control Connector
- 6. Remote Torch Control Connector
- 7. Positive power connector
- 8. Mains switch
- 9. Adjustment control

Rear Machine Layout Description



- 10. Data Plate
- 10. Primary Input Power Lead
- 12. Gas Inlet Connector
- 13. Serial Number Plate



Front Panel Selector Keys

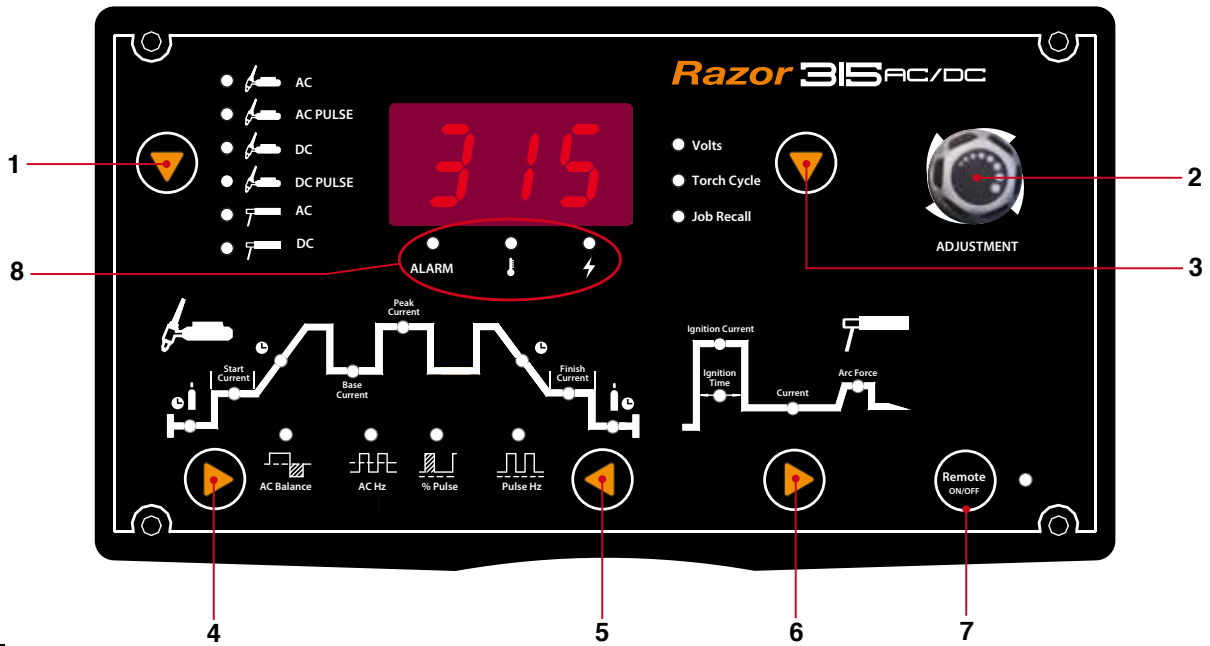

Indicates Action Selector Key

**1. Mode Selector :** Enables selection of required welding mode -  
 AC TIG - AC PULSE TIG - DC TIG - DC PULSE TIG.  
 AC MMA (Stick Electrode) - DC MMA (Stick Electrode)

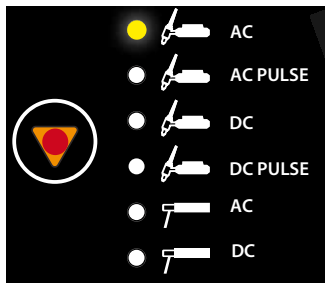

**AC TIG:** Select by pushing the selector key to cycle through to illuminate the AC icon.

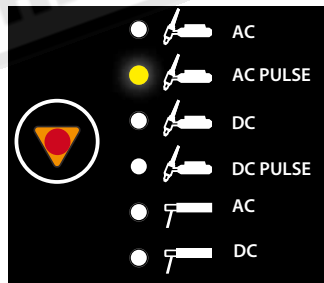

**AC Pulse TIG:** Select by pushing the selector key to cycle through to illuminate AC Pulse icon.

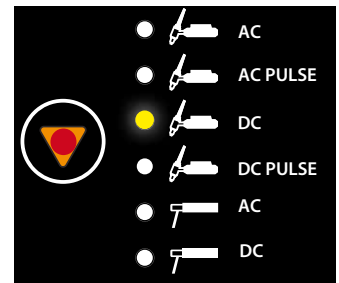

**DC TIG:** Select by pushing the selector key to cycle through to illuminate DC Pulse icon.

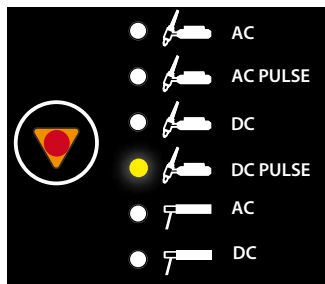

**DC Pulse TIG:** Select by pushing the selector key to cycle through to illuminate DC Pulse icon.

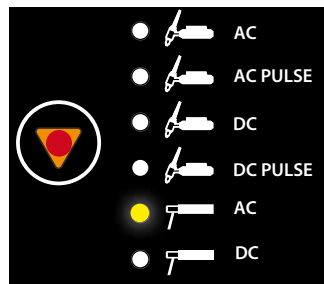

**AC MMA:** Select by pushing the selector key to cycle through to illuminate AC icon.

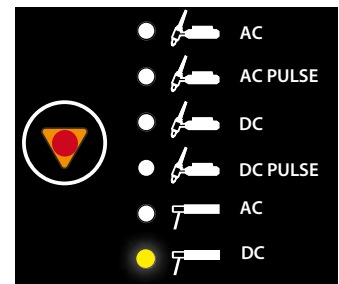

**DC MMA:** Select by pushing the selector key to cycle through to illuminate DC icon.



**2. Adjustment Encoder Knob** - provides digital adjustment of welding parameters and weld selection cycles



The **Adjustment Encoder Knob** is used to set the value of the parameters required. Turning the encoder will adjust the value shown in the digital display screen.

- 3. Voltage Display Selector:** When selected shows the output voltage on the digital display.
- Torch Cycle Selector:** Controls the on/off cycle of the machine using the torch switch while incorporating the weld program parameters selections.
- Job Recall Selector:** Allows the setting and recall of welding parameters. 5 job settings and memory recalls for each welding mode. See page 17 for operational instruction



**Volts:** Select the Volts icon using the selector key.

The digital display will show the output voltage present for the welding mode selected



**Torch Cycle:** Select the Torch Cycle icon using the selector key.

Turn the encoder to select the torch cycle desired.



The digital display will show the torch cycle mode selected



**2T:** Select the 2T cycle using the adjustment encoder knob. 2T uses 2 actions of the torch switch while incorporating weld program parameter selections. (refer to page 23 for instruction of 2T function)

**4T:** Select the 4T cycle using the adjustment encoder knob. 4T uses 4 actions of the torch switch while incorporating weld program parameter selections. (refer to page 23 for instruction of 4T function)

#### 4. Weld Program - Provides selection weld program parameters

**Parameter selection:** Select by pushing selector  pad to cycle through to illuminate the icon  of the parameter required. Each push of the selector pad will move the icon illumination in a clockwise cycle.

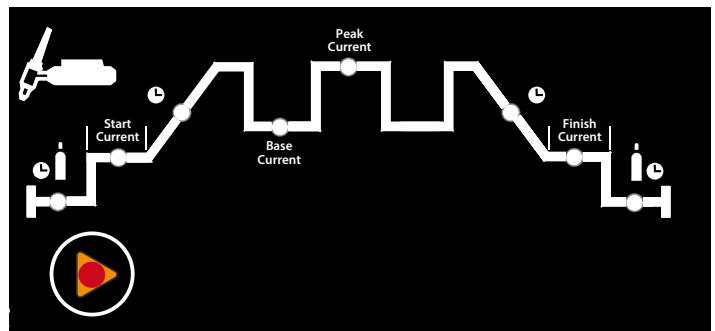

#### Pre Gas Timer - Provides selection for gas flow time prior to the arc starting.

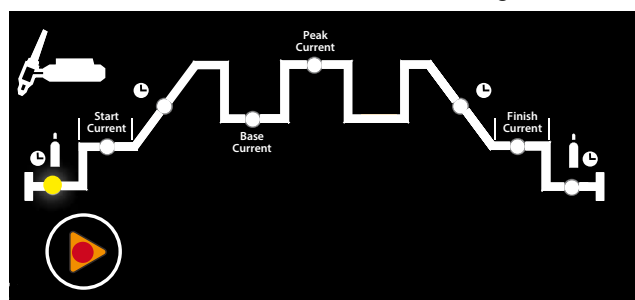

**Pre Gas Time:** Select by pushing selector key to cycle through to illuminate the Pre Gas Timer  icon.



Turn the Encoder to set the Pre-Gas Time (Range is 0-15 Sec)



The value selected shows on the digital display. It is the length of time the gas will flow before the arc starts.

#### Start Current - Provides selection for the amount of amps required at the start of the weld.

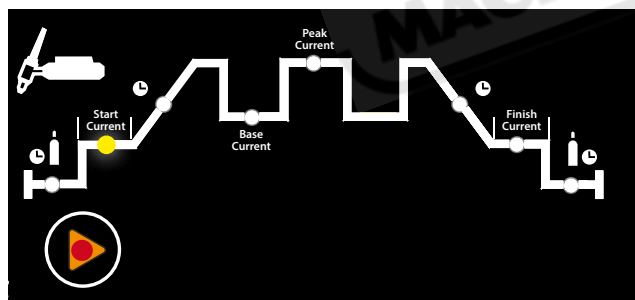

**Pre Gas Time:** Select by pushing selector key to cycle through to illuminate the Start Amp icon.

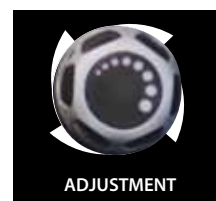



Turn the Encoder to set the Start Current value DC Range 10~320 AC Range 20~250

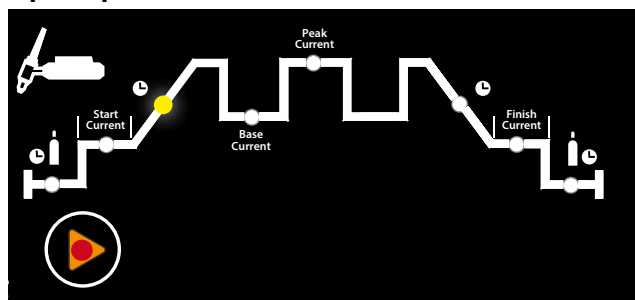

The value selected shows on the digital display. It is the amount of amps the machine will deliver at the start of the welding sequence.

#### Up Slope Time - Sets the transition time from Start Amperage to Welding Amperage



**Up Slope Time:** Select by pushing selector key to cycle through to illuminate the Up Slope icon. 

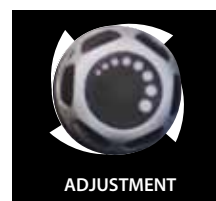

Turn the Encoder to set the Pre-Gas Time (Range is 0-60 Sec)



The value selected shows on the digital display. It is the amount of time the welding current takes to climb from start amperage to welding amperage.

**Base Current** - Provides selection for the Base Amperage during the Pulse Welding cycle.

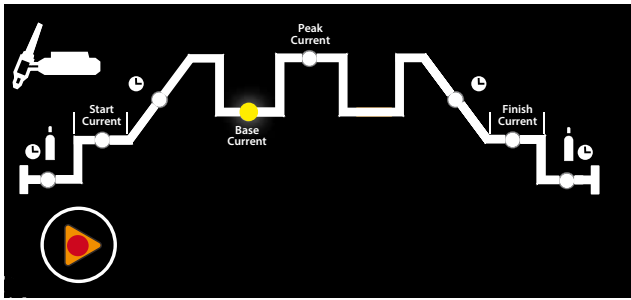

**Base Amp:** Select by pushing selector key to cycle through to illuminate the Base Current icon.

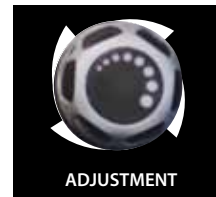

DC Range 10~320  
AC Range 20~320



**Peak Current** - Provides selection for the Maximum Welding Current (Amps) required during welding.

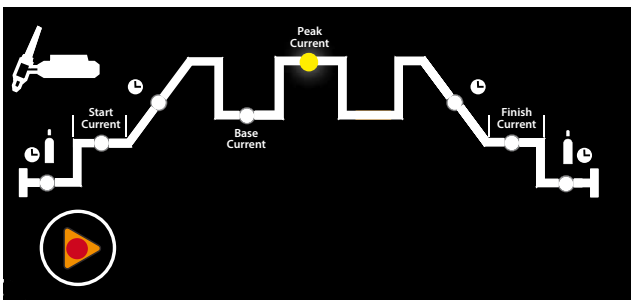

**Peak Current:** Select by pushing selector key to cycle through to illuminate the Peak Current icon.

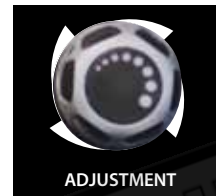

DC Range 10~320  
AC Range 20~320



**Down Slope Time** - Sets the transition time from Start Amperage to Welding Amperage

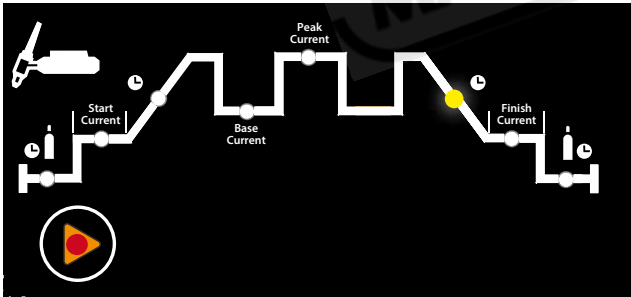

**Down Slope Time:** Select by pushing selector key to cycle through to illuminate the Down Slope icon.

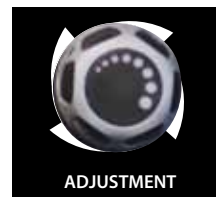

(Range is 0~60 Sec)



**Finish Current** - Provides selection for the amount of amps required at the end of the weld.

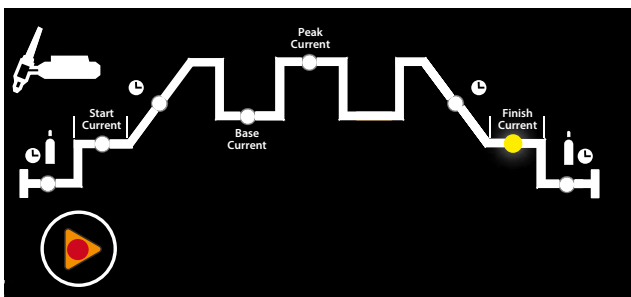

**Finish Amp:** Select by pushing selector key to cycle through to illuminate the Finish Amp icon.



DC Range 10~320  
AC Range 20~250



**Post Gas Timer** - Provides selection for continued gas flow time at the end of the welding after the arc is out.

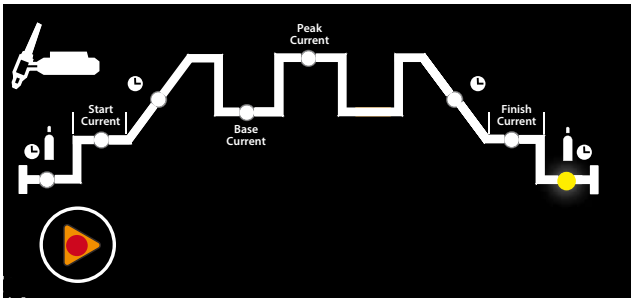

**Pre Gas Time:** Select by pushing selector key to cycle through to illuminate the Post Gas Timer icon. 



Turn the Encoder to set the Pre-Gas Time (Range is 0-10 Sec)



The value selected shows on the digital display. It is the length of time the gas will flow after the arc is finished.

**5. Pulse Mode Parameter Selection:** Provides setting of the parameters for Pulse Frequency and Pulse Duty in AC Pulse TIG and DC Pulse TIG Modes.

**AC Wave Frequency Selection:** Provides setting of the AC Wave Frequency (Hz) in AC TIG Mode  
**AC Wave Balance Selection:** Provides setting of AC Wave + / - Balance in AC TIG Mode

**Pulse Frequency** - Provides setting of the amount of pulses per second of the Peak Current.

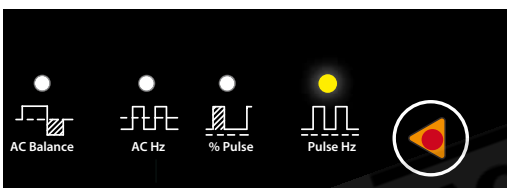

**Pulse Frequency:** Select by pushing selector key to cycle through to illuminate the Pulse Hz icon.

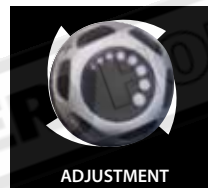

Turn the Encoder Knob to set the Pulse Frequency  
 DC Range 0.5~200Hz  
 AC Range 0.5~5.0Hz



The value selected is shown in the digital display. The value selected is the amount of pulses per second (Hz)

**Pulse Duty** - Provides setting of the % of time the peak current stays on within each pulse cycle.

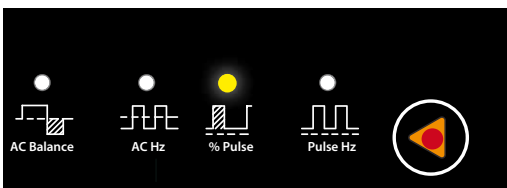

**Pulse Duty:** Select by pushing selector key to cycle through to illuminate the % Pulse icon.

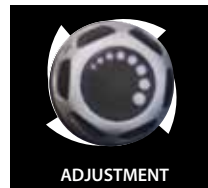

Turn the Encoder Knob to set the Pulse Width (Range is 10 - 90%).



The value selected is shown in the digital display. The value selected is the % of ON time of the Peak Current during each pulse cycle.

**AC Hz** - Provides setting of the frequency that the direction of the AC wave (+ to -) completes a full cycle

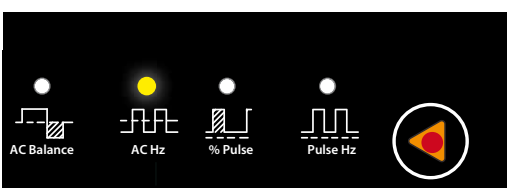

**AC Hz:** Select by pushing selector pad to cycle through to illuminate the AC Hz icon.

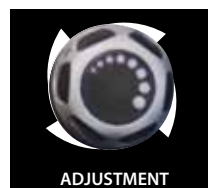

Turn the Encoder Knob to set the Pulse Width (Range is 20-70 Hz).



The value selected is shown in the digital display. The value selected is how many times per second the AC wave completes a full cycle.

**AC Balance** - Provides setting of the % of on time of the electrode negative portion of the AC Wave output current.



**AC Balance:** Select by pushing selector pad to cycle through to illuminate the AC Hz icon.

Turn the Encoder Knob to set the AC Balance (Range is 10-60 %).

The value selected is shown in the digital display. The value selected is the % of time that the current flow remains at electrode negative during each AC cycle. (See pages for 30-31-34 for more AC Wave Balance information)

**6. MMA Mode Parameter Selection:** Provides setting of the parameters for MMA Ignition Current, Ignition Time and Welding Current output.

**Ignition Current** - Provides setting of the amount of current (amps) delivered at the striking of the arc allowing customised starting arc characteristic of the electrode. Setting a lower current value than the main welding current will place the machine in a low current arc ignition mode providing a lift arc style soft start arc ignition. Higher current setting provides contact arc ignition, touching the electrode to the work piece establishes a short circuit whereby the higher ignition current is applied allowing welding without lifting the electrode.



**Ignition Current:** Select by pushing selector key to cycle through to illuminate the Ignition Current icon.

Turn the Encoder Knob to set the Ignition Current level.  
DC Range 10~300A  
AC Range 20~300A

The value selected is shown in the digital display. The value selected is the amount amps delivered at the striking of the arc in MMA Mode. (Stick Electrode)

**Ignition Time** - Provides setting of the amount Time that the Ignition Current is on.



**Ignition Time:** Select by pushing selector key to cycle through to illuminate the Ignition Current icon.

Turn the Encoder Knob to set the Ignition Current level. (Range is 0.01- 1.0 sec)

The value selected is shown in the digital display. The value selected is the amount time that ignition current is applied at the striking of the arc.

**Current** - Provides setting of the main welding current (amps) delivered in MMA Mode (stick electrode).

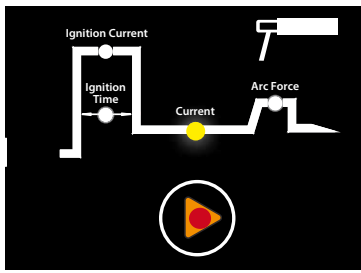

**Current:** Select by pushing selector key to cycle through to illuminate the Current icon.

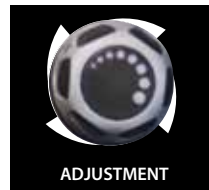

Turn the Encoder Knob to set the Ignition Current level.  
DC Range 10~250A  
AC Range 20~250A



The value selected is shown in the digital display. The value selected is the amount current (amps) delivered during welding in MMA Mode. (Stick Electrode)

**Arc Force** - Provides setting of extra current being applied to the electrode when the arc length becomes short preventing the electrode from sticking during welding. The more Arc Force applied the more aggressive and digging becomes the arc and less chance of the electrode sticking to the work piece. The less Arc Force applied the smoother and softer is the arc characteristic. The required Arc Force is dependant on the type of electrode, application and operator preference.

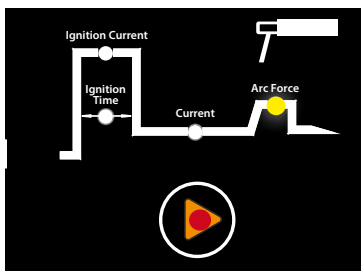

**Arc Force:** Select by pushing selector key to cycle through to illuminate the Arc Force icon.

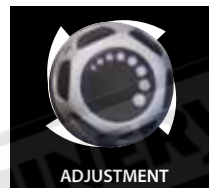

Turn the Encoder Knob to set the Arc Force level. (Range is 0-100)



The value selected is shown in the digital display. The value selected is the amount of Arc Force applied to the electrode during welding.

**7. Remote ON/OFF :** Provides use of remote amperage controls. Functional in TIG mode only.

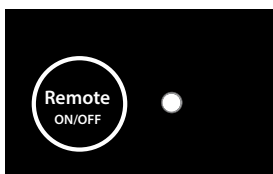

**Remote :** Select by pushing the Remote ON/OFF key. The led will flash when the remote function is on.



The minimum welding current will be 30 amps - the maximum obtainable welding current will be as is preset at the machine.



The adjusting welding current will be displayed at the digital meter in real time while the remote control is being used. Remote control is functional in TIG mode only.

1. No LED Remote is OFF
2. Press button once  
LED Light is Solid and ready to activate
3. Press button twice and LED Light is Flashing  
Remote control is activated

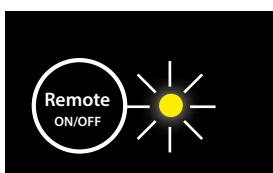



**7. LED Display Functions - Alarms :** Provides display of parameters and alarm codes.

**Parameter Display -** Provides display of parameter settings.

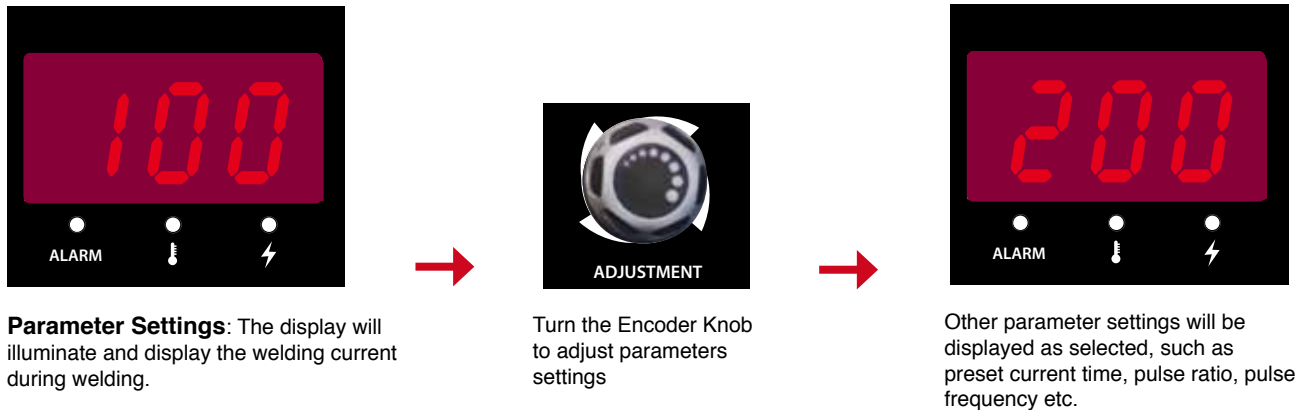

**Software Version Display -** Provides display of the Version Software

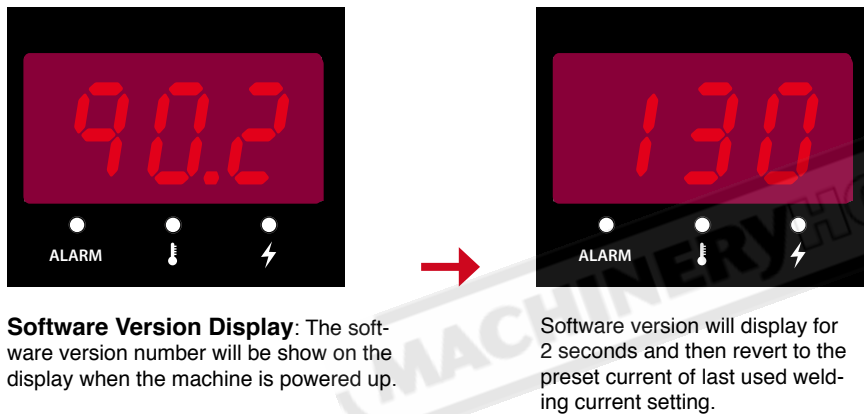

**Alarm LEDs -** Provides display of alarm condition and error code.

In normal condition, all alarm LEDs are off. In case of any error, the corresponding LED will illuminate and the digital meter will display the corresponding error code

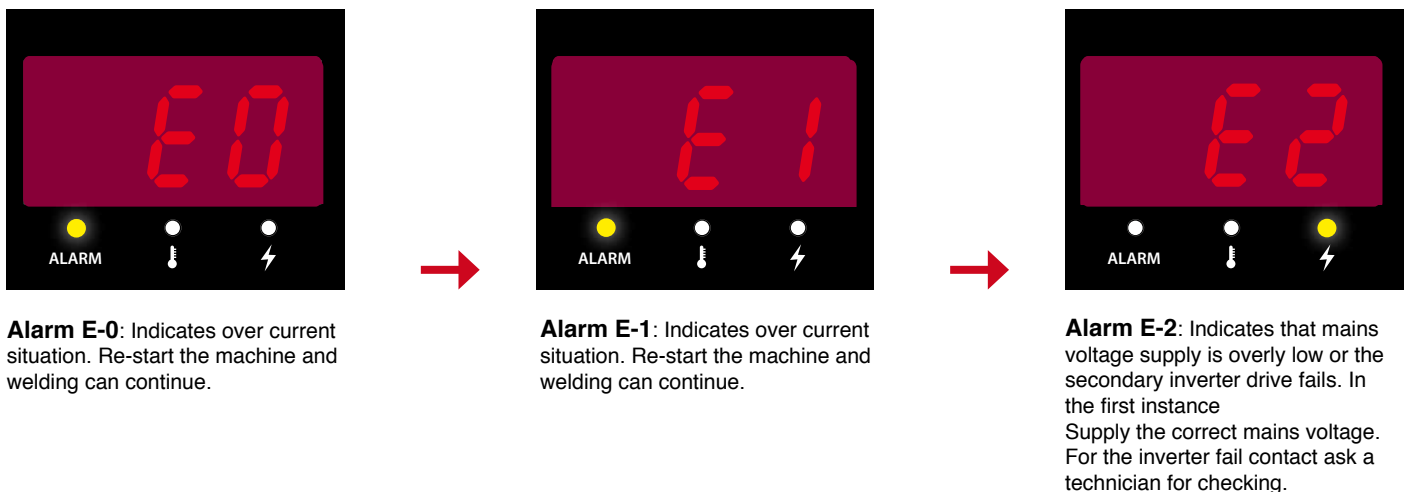

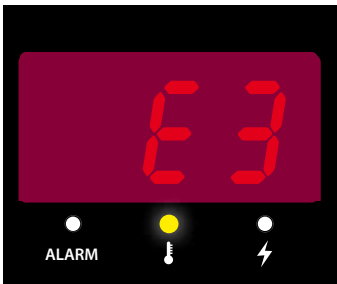

**Alarm E-3:** Indicates the machine has over heated and the thermal switch has activated. Leave the machine on to allow the fan to cool the machine and recover.



**Alarm E-4:** Indicates the main circuit of the machine has over-heated. Leave the machine on to allow the fan to cool the machine and recover.

**Welding Parameter Storage Job recall** Allows the setting and recall of welding parameters. 5 job settings and memory recalls for each welding mode.

The parameters having been adjusted will be auto saved in the Job number currently in use. No auto saving will happen if welding is not carried out after the parameters have been changed. When the machine is turned on it will revert to the last welding parameters used for that selected Job. There is no manual save function available.

Allows users to save welding parameters based on the welding application in use for a total of 5 Jobs in each welding mode. 5 Jobs for each of the six welding modes available.

When the machine is turned on the last Job used welding parameters will be displayed. If a new Job number is not selected the machine will continue to work under the current Job.

Note: (Parameters in all the five Job groups are the same as default when using the machine for the first time.)

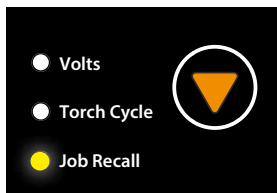

**Job Recall:** Select the Job Recall icon using the selector pad.

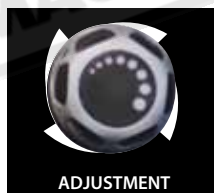

Turn the encoder to select the Job number required.



The digital display will show the Job number recalled.

## MMA (Stick Electrode) Welding Set and Operation

- (1) **Connecting the Welding Lead Set:** Various electrodes require a different polarity for optimum results refer to the electrode manufacturers information for the correct polarity. Most GP electrodes are Electrode connected to  $\oplus$  output socket, Earth Connected to the  $\ominus$  output socket
- (2) Turn the power source on using the on/off switch located on the front control panel.
- (3) Select you preferred MMA mode using the MODE selector key.



### MMA - Current Set

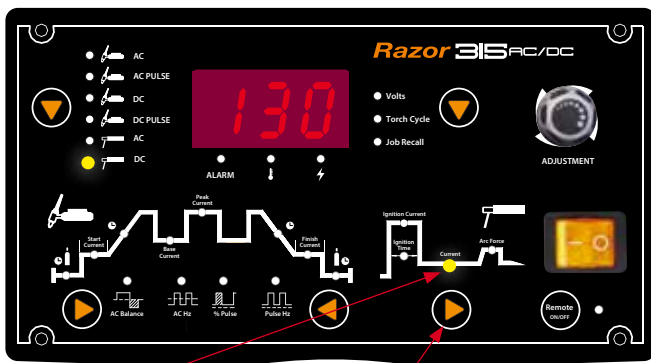

- (4) Select the Welding Current push the **Current** key until the **Current** icon is illuminated. Set the weld amperage by rotating the **Adjustment Knob**. Set the amperage according to the electrode type and size as recommended by the electrode manufacturer. The the set amperage will show in the **Digital Display**.

### MMA - Ignition Current Set

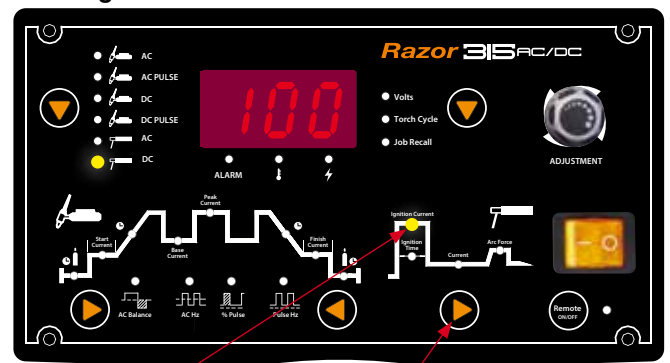

- (5) Select **Ignition Current**. Push the **Ignition Current** key until the **Ignition Current** icon illuminates. Turn the **Adjustment Knob** to set the **Ignition Current**, the set current will be shown on the **Digital Display**. Refer to Page 14 for instruction on **Ignition Current**.

## MMA - Ignition Time Set

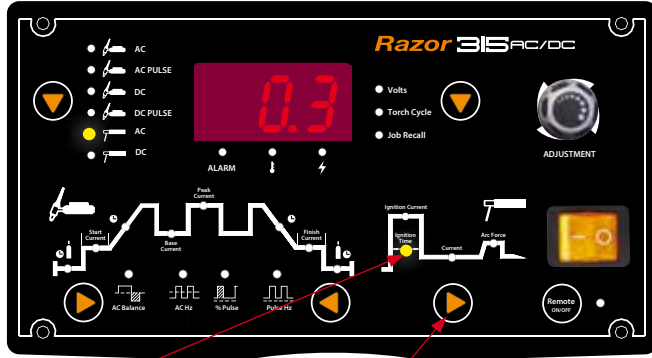

(6) Select the Ignition Time. Push the  key until the Ignition time icon is illuminated. Set the Ignition time by rotating the Adjustment Knob. The set Ignition time will show in the Digital Display. Refer to Page 14 for instruction on Ignition Time.

## MMA - Arc Force Set.

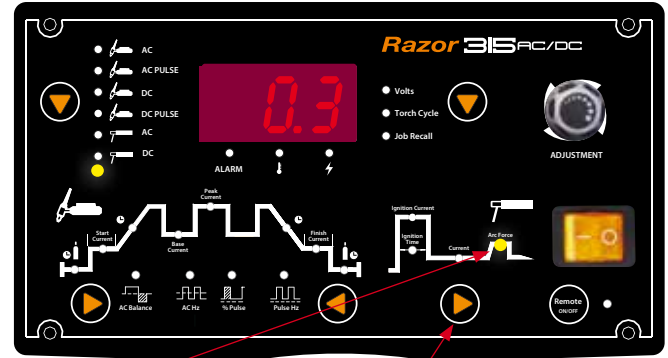

(7) To set the Arc Force push the same  key until the Arc Force icon illuminates. Turn the Adjustment Knob to set the Arc Force, the set value will be shown on the Digital Display. Refer to Page 15 for instruction on Arc Force.

## MMA (Stick Electrode) Welding



6) Connect the Earth Clamp securely to the work piece or the work bench.



7) Place and clamp an electrode into the Electrode Hand Piece



8) Strike the electrode against the work piece to create an arc, lift slightly and hold the electrode steady to maintain the arc



9) Hold the electrode slightly above the work maintaining the arc while travelling at an even speed.



10) To finish the weld, break the arc by quickly snapping the electrode away from the work piece.



11) Wait for the weld to cool and carefully chip away the slag to reveal the weld metal below.

# MMA (Manual Metal Arc) Welding

One of the most common types of arc welding is manual metal arc welding (MMA) or stick welding. An electric current is used to strike an arc between the base material and a consumable electrode rod or 'stick'. The electrode rod is made of a material that is compatible with the base material being welded and is covered with a flux that gives off gaseous vapours that serve as a shielding gas and providing a layer of slag, both of which protect the weld area from atmospheric contamination. The electrode core itself acts as filler material the residue from the flux that forms a slag covering over the weld metal must be chipped away after welding.

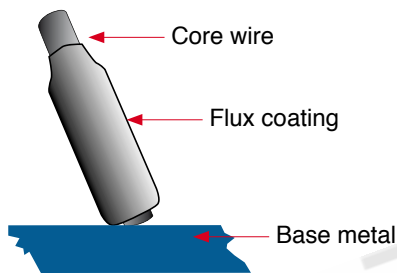
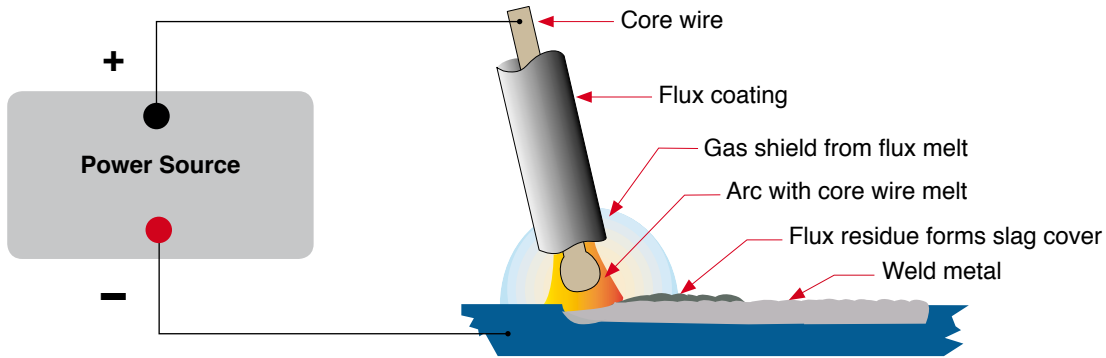

- The arc is initiated by momentarily touching the electrode to the base metal.
- The heat of the arc melts the surface of the base metal to form a molten pool at the end of the electrode.
- The melted electrode metal is transferred across the arc into the molten pool and becomes the deposited weld metal.
- The deposit is covered and protected by a slag which comes from the electrode coating.
- The arc and the immediate area are enveloped by an atmosphere of protective gas

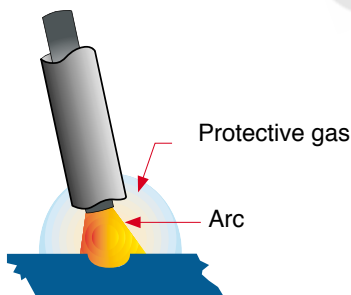

Manual metal arc (stick) electrodes have a solid metal wire core and a flux coating. These electrodes are identified by the wire diameter and by a series of letters and numbers. The letters and numbers identify the metal alloy and the intended use of the electrode.

The **Metal Wire Core** works as conductor of the current that maintains the arc. The core wire melts and is deposited into the welding pool.

The covering on a shielded metal arc welding electrode is called **Flux**. The flux on the electrode performs many different functions. These include:

- producing a protective gas around the weld area
- providing fluxing elements and deoxidizers
- creating a protective slag coating over the weld as it cools
- establishing arc characteristics
- adding alloying elements.

Covered electrodes serve many purposes in addition to adding filler metal to the molten pool. These additional functions are provided mainly by the covering on the electrode.

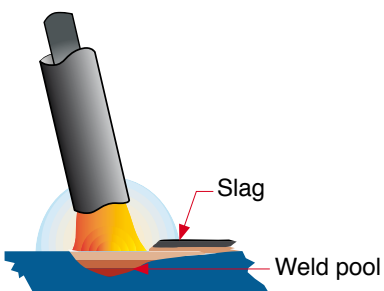



# MMA (Stick) Welding Fundamentals

## Electrode Selection

As a general rule, the selection of an electrode is straight forward, in that it is only a matter of selecting an electrode of similar composition to the parent metal. However, for some metals there is a choice of several electrodes, each of which has particular properties to suit specific classes of work. It is recommended to consult your welding supplier for the correct selection of electrode.

## Electrode Size

Average Thickness of Material	Maximum Recommended Electrode Diameter	Current Range (Amps)
1.0 - 2.0mm	2.5mm	60 - 95
2.0 - 5.0mm	3.2mm	100 - 130
5.0 - 8.0mm	4.0mm	130 - 165
8.0 - > mm	5.0mm	165 - 260

The size of the electrode generally depends on the thickness of the section being welded, and the thicker the section the larger the electrode required. The table gives the maximum size of electrodes that may be used for various thicknesses of section based on using a general purpose type 6013 electrode.

## Welding Current (Amperage)

Correct current selection for a particular job is an important factor in arc welding. With the current set too low, difficulty is experienced in striking and maintaining a stable arc. The electrode tends to stick to the work, penetration is poor and beads with a distinct rounded profile will be deposited. Too high current is accompanied by overheating of the electrode resulting in undercut and burning through of the base metal and producing excessive spatter. Normal current for a particular job may be considered as the maximum, which can be used without burning through the work, overheating the electrode or producing a rough spattered surface.

The table shows current ranges generally recommended for a general purpose type 6013 electrode.

## Arc Length

To strike the arc, the electrode should be gently scraped on the work until the arc is established. There is a simple rule for the proper arc length; it should be the shortest arc that gives a good surface to the weld. An arc too long reduces penetration, produces spatter and gives a rough surface finish to the weld. An excessively short arc will cause sticking of the electrode and result in poor quality welds. General rule of thumb for down hand welding is to have an arc length no greater than the diameter of the core wire.

## Electrode Angle

The angle that the electrode makes with the work is important to ensure a smooth, even transfer of metal. When welding in down hand, fillet, horizontal or overhead the angle of the electrode is generally between 5 and 15 degrees towards the direction of travel. When vertical up welding the angle of the electrode should be between 80 and 90 degrees to the work piece.

## Travel Speed

The electrode should be moved along in the direction of the joint being welded at a speed that will give the size of run required. At the same time, the electrode is fed downwards to keep the correct arc length at all times. Excessive travel speeds lead to poor fusion, lack of penetration etc, while too slow a rate of travel will frequently lead to arc instability, slag inclusions and poor mechanical properties.

## Material and Joint Preparation

The material to be welded should be clean and free of any moisture, paint, oil, grease, mill scale, rust or any other material that will hinder the arc and contaminate the weld material. Joint preparation will depend on the method used include sawing, punching, shearing, machining, flame cutting and others. In all cases edges should be clean and free of any contaminants. The type of joint will be determined by the chosen application.



## TIG Welding Set and Operation

- (1) Connect the **TIG Torch** connector to the **negative terminal** and tighten it
- (2) Connect the torch switch remote lead into the torch remote socket
- (3) Insert the torch gas connector into the quick lock gas receptacle
- (4) Connect the **Earth Cable** connector into the **positive terminal** and tighten it
- (5) **(A)** Connect gas line to Gas Regulator and connect the gas regulator to the Gas Cylinder  
**(B)** Connect the gas line to the quick lock gas inlet connector at the rear of the machine  
**(C)** Slowly open the cylinder valve.  
**(D)** Set the flow rate on the regulator to approximately 8 -12 l/min.  
**(E)** Close the cylinder valve and pay attention to the needle indicator of the contents pressure gauge on the regulator, if the needle drops away towards zero there is a gas leak. Sometimes a gas leak can be slow and to identify it will require leaving the gas pressure in the regulator and line for an extended time period. In this situation it is recommended to open the cylinder valve, set the flow rate to 8 -12 l/min, close the cylinder valve and check after a minimum of 15 minutes.  
**(F)** If there is a gas loss then check all connectors and clamps for leakage by brushing or spraying with soapy water, bubbles will appear at the leakage point.  
**(G)** Tighten clamps or fittings to eliminate gas leakage **.Important:** We strongly recommend that you check for gas leakage prior to operation of your machine. We recommend that you close the cylinder valve when the machine is not in use.
- (6) Turn on the machine using the **ON/OFF** switch
- (7) Select the preferred **TIG** function with the **MODE** selector switch



HF (high frequency) ignition allows the arc to be started in TIG welding without touching the tungsten to the work piece. By pressing the torch switch the machine will activate the gas flow and the HF ignition resulting in the arc igniting across the gap between the tungsten electrode and the work piece. The distance between the electrode and the work piece can be up to 5mm. This arc ignition method prevents tungsten inclusion in the work piece, promotes longer tungsten life and offers better operator control over the starting and stopping the arc.

- (1) Assemble the front end torch parts use the correct size and type of tungsten electrode for the job, the tungsten electrode requires a sharpened point for DC welding.
- (2) Select **DC TIG** and choose **2T** or **4T** trigger function preferred as per the descriptions below
  - 2T Selection** provides 2 times function of the torch switch.
    - (1) Pressing the torch switch gives arc ignition and initializes the welding current and the welding current is maintained by the torch remaining on.
    - (2) Releasing the torch switch stops the welding by introducing down slope and the current falls to minimum level and then terminates the welding current and introduces the post flow gas.
  - 4T Selection** provides 4 times function of the torch switch
    - (1) Pressing the torch switch gives arc ignition and initializes the welding current
    - (2) Releasing the torch switch continues the welding operation.
    - (3) Pressing the torch switch and holding introduces down slope and current falls to minimum current.
    - (4) Releasing the torch switch terminates the welding operation and introduces the post flow gas.
- (3) Choose the preferred welding current (amperage) to suit the tungsten size material type and thickness to be welded.
- (4) Lay the outside edge of the Gas Cup on the work piece with the Tungsten Electrode 1- 3mm from the work piece this method will provide a clean positive arc ignition.
- (5) Press the torch switch and the arc will ignite across the gap between the tungsten and work piece. Hold even distance of about 2mm gap between the tungsten and work piece to maintain the arc.
- (6) Release the torch switch to bring in the end of the welding sequence dependant of 2T or 4T trigger function choice.



(1) Assemble the front end torch parts use the correct size and type of tungsten electrode for the job, the tungsten electrode requires a sharpened point for DC welding

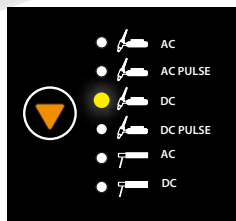

(2) Select **DC TIG** Function. Push the  key until the **DC TIG** icon illuminates

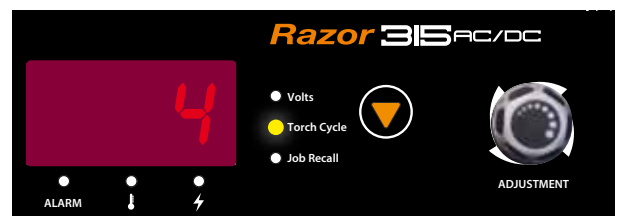

(3) Select **2** or **4** trigger function as required by the pushing the  key until the Torch Cycle icon illuminates. Turn the Adjustment knob to select the option shown on the digital display. Press the torch switch to exit Torch Cycle mode. The display will default to the set welding current, adjust the set current using the Adjustment knob.



(4) Lay the outside edge of the Gas Cup on the work piece with the Tungsten Electrode 1- 3mm from the work piece



(5) Press the torch switch and the arc will ignite across the gap between the tungsten and work piece. Hold even distance of about 2mm gap between the tungsten & work piece to maintain the arc.



(6) Release the torch switch to bring in the end of the welding sequence dependant of 2T or 4T trigger function choice

# DC TIG Welding

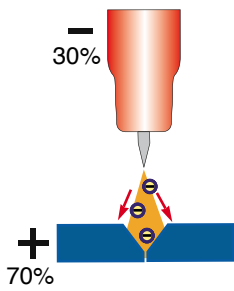

The DC power source uses what is known as DC (direct current) in which the main electrical component known as electrons flow in only one direction from the negative pole (terminal) to the positive pole (terminal). In the DC electrical circuit there is an electrical principle at work which should always be taken into account when using any DC circuit. With a DC circuit 70% of the energy (heat) is always on the positive side. This needs to be understood because it determines what terminal the TIG torch will be connected to (this rule applies to all the other forms of DC welding as well ).

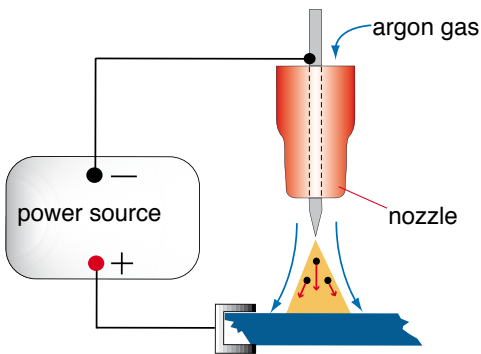

DC TIG welding is a process in which an arc is struck between a TUNGSTEN electrode and the metal work piece. The weld area is shielded by an inert gas flow to prevent contamination of the tungsten, molten pool and weld area.

When the TIG arc is struck the inert gas is ionized and superheated changing it's molecular structure which converts it into a plasma stream. This plasma stream flowing between the tungsten and the work piece is the TIG arc and can be as hot as 19,000°C. It is a very pure and concentrated arc which provides the controlled melting of most metals into a weld pool. TIG welding offers the user the greatest amount of flexibility to weld the widest range of material and thickness and types. DC TIG welding is also the cleanest weld with no sparks or spatter.

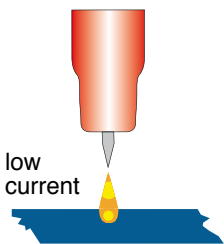

The intensity of the arc is proportional to the current that flows from the tungsten. The welder regulates the welding current to adjust the power of the arc. Typically thin material requires a less powerful arc with less heat to melt the material so less current (amps) is required, thicker material requires a more powerful arc with more heat so more current (amps) are necessary to melt the material.

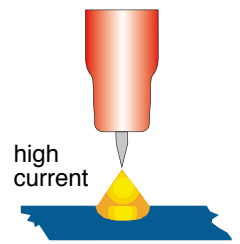

## HF ARC IGNITION for TIG (tungsten inert gas) Welding

HF (high frequency) ignition allows the arc to be started in TIG welding without touching the tungsten to the work piece. By pressing the torch switch the machine will activate the gas flow and introduce the HF (high frequency) (high voltage) spark, this "ionizes" the air gap making it conductive allowing an arc to be created without touching the tungsten to the work piece. The gas molecules are superheated by the arc creating a stream of super heated gas that changes the molecular structure into producing a plasma stream. This plasma stream provides heat and energy that allows us to melt and fuse metals in an inert gas shielded environment know as TIG (tungsten inert gas) welding.

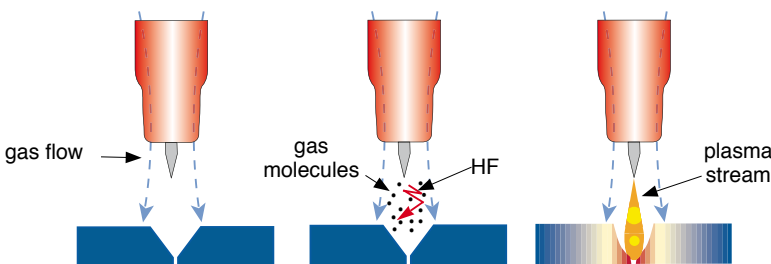

## TIG Welding Fusion Technique

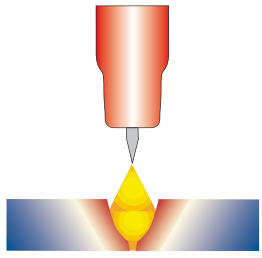

Manual TIG welding is often considered the most difficult of all the welding processes. Because the welder must maintain a short arc length, great care and skill are required to prevent contact between the electrode and the work piece. Similar to Oxygen Acetylene torch welding, TIG welding normally requires two hands and in most instances requires the welder to manually feed a filler wire into the weld pool with one hand while manipulating the welding torch in the other. However, some welds combining thin materials can be accomplished without filler metal like edge, corner, and butt joints.

This is known as Fusion welding where the edges of the metal pieces are melted together using only the heat and arc force generated by the TIG arc. Once the arc is started the torch tungsten is held in place until a weld pool is created, a circular movement of the tungsten will assist in creating a weld pool of the desired size. Once the weld pool is established tilt the torch at about a 75° angle and move smoothly and evenly along the joint while fusing the materials together.

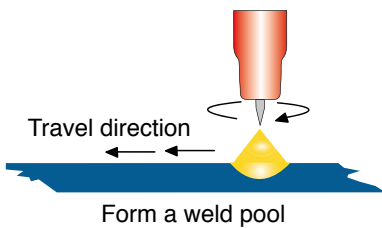

Form a weld pool

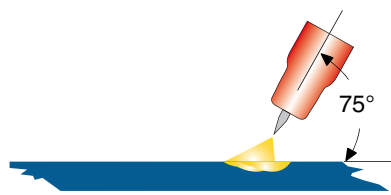

Angle torch

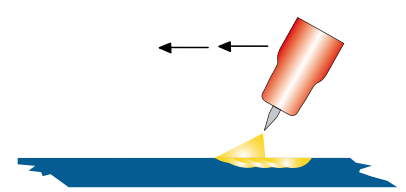

Move the torch slowly and evenly forward

## TIG Welding with Filler Wire Technique

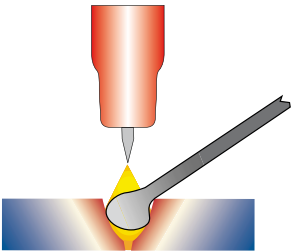

It is necessary in many situations with TIG welding to add a filler wire into the weld pool to build up weld reinforcement and create a strong weld. Once the arc is started the torch tungsten is held in place until a weld pool is created, a circular movement of the tungsten will assist in creating a weld pool of the desired size. Once the weld pool is established tilt the torch at about a 75° angle and move smoothly and evenly along the joint. The filler metal is introduced to the leading edge of the weld pool. The filler wire is usually held at about a 15° angle and fed into the

leading edge of the molten pool, the arc will melt the filler wire into the weld pool as the torch is moved forward. Also a dabbing technique can be used to control the amount of filler wire added, the wire is fed into the molten pool and retracted in a repeating sequence as the torch is moved slowly and evenly forward. It is important during the welding to keep the molten end of the filler wire inside the gas shield as this protects the end of the wire from being oxidised and contaminating the weld pool.

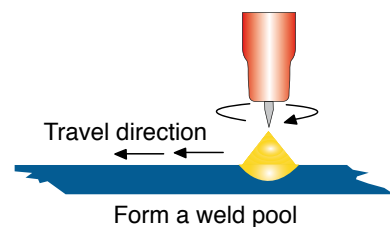

Form a weld pool

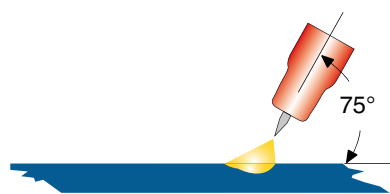

Angle torch

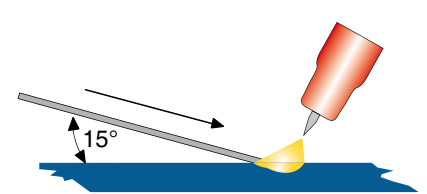

Add Tig filler wire

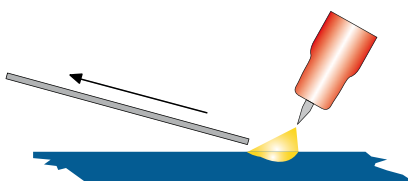

Retract the filler wire

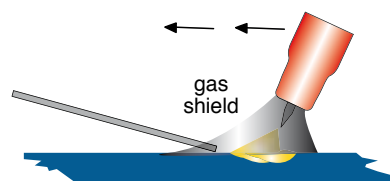

Move the torch forward to the front of the weld pool

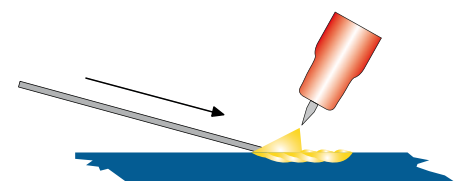

Repeat the process

# DC Pulse TIG Welding

Pulse TIG welding is when the current output (amperage) changes between high and low current. Electronics within the welding machine create the pulse cycle. Welding is done during the high-amperage interval (this high amperage is referred to as peak current). During the low amperage period, the arc is maintained but the current output of the arc is reduced (this low amperage is referred to as base current). During pulse welding the weld pool cools during the low amperage period. This allows a lower overall heat input into the base metal. It allows for controlled heating and cooling periods during welding providing better control of heat input, weld penetration, operator control and weld appearance.

There are 4 variables within the pulse cycle:

Peak Current - Base Current - Pulse Frequency - Pulse Width

Setting and manipulation of these variables will determine the nature of the weld current output and is at the discretion of the operator.

**Peak Current** is the main welding current (amps) set to melt the material being welded and works much the same as setting maximum amperage values for regular DC TIG: as a guide use 30-40 amps for every 1mm of material thickness.

**Base Current** is the set level of background current (amps) which cools the weld puddle and affects overall heat input. Background Amps is a percentage of peak amperage. As a rule, use enough background current to reduce the weld pool to about half its normal size while still keeping the weld pool fluid. As a guide start by setting the background amperage at 20 to 30 percent of peak amperage.

**Pulse Frequency** is the control of the amount of times per second (Hz) that the welding current switches from Peak Current to Base Current. DC Pulse TIG frequency ranges from 0.5 to 200 HZ depending on the job application. Control of the pulse frequency also determines the appearance of the weld.

**Pulse Width** is the control of the percentage of time during one pulsing cycle the power source spends at the peak current (main amperage). Example is with the Pulse Width set at 80 percent and a rate of 1 pulse per second (PPS), the machine will spend 80% of the pulse at peak amperage and 20% at the base current. Increasing the pulse width percentage adds more heat to the job, while decreasing pulse width percentage reduces heat

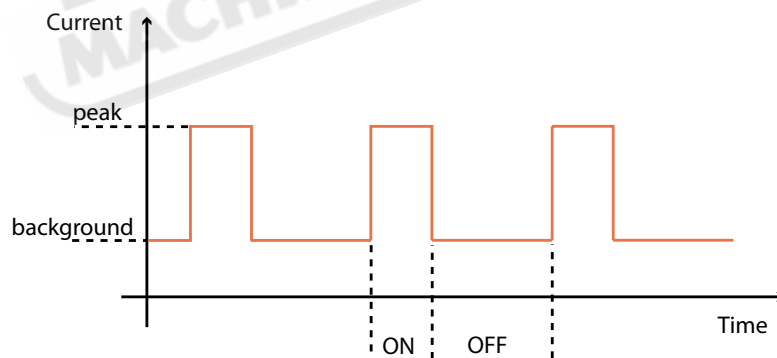

DC Pulse TIG welding allows faster welding speeds with better control of the heat input to the job, reducing the heat input minimising distortion and warping of the work and is of particular advantage in the welding of thin stainless steel and carbon steel applications. The high pulse frequency capability of the advanced inverter agitates the weld puddle and allows you to move quickly without transferring too much heat to the surrounding metal. Pulsing also constricts and focuses the arc thus increasing arc stability, penetration and travel speeds.

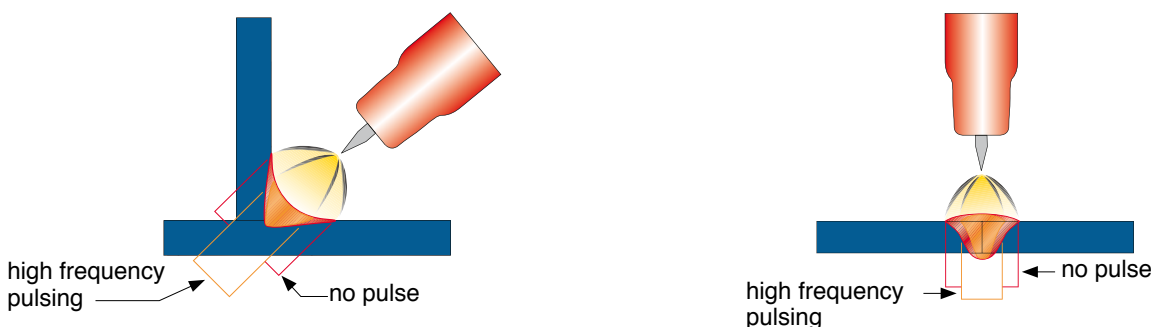



# Set up and operation for DC PULSE TIG Welding

The Razorweld 315 machine has digital pulse frequency control. All the parameters for DC Pulse TIG welding - Peak Amp, Base Amp, Pulse Frequency and Pulse Width are easy to set via the digital control panel.

## EXAMPLE OF PULSE DC TIG WELDING - SETUP PARAMETERS:

**Material = Stainless Steel x 2.0mm / Tungsten Electrode = 1.6mm 2% Thoriated / Gas = Argon**

The following steps are a guide as a starting point for you to set the machine up in Pulse mode to give an example of welding in Pulse mode function. You can experiment by changing any of the variables to see what effect it has over the welding and what the end result can be, but it is suggested to change only one variable at a time and then check the welding to see what the result is, in this way you acquire a better understanding of how each variable affects the welding current.

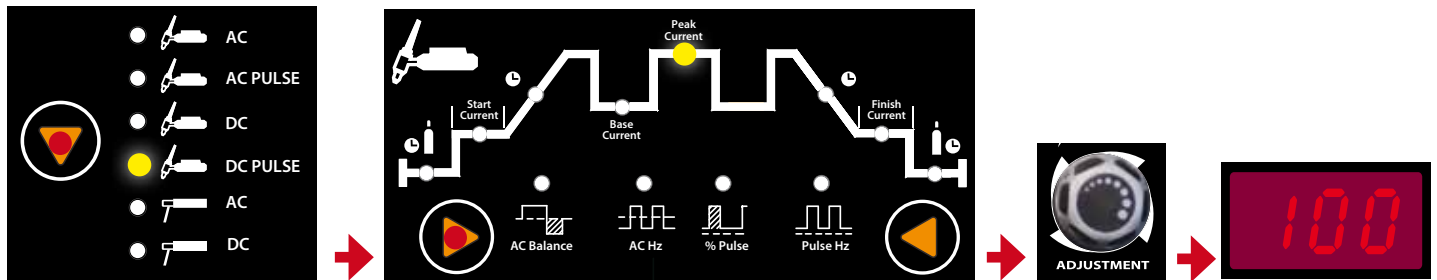

1. Select DC Pulse by pushing selector key to cycle through to illuminate DC Pulse icon.

2. Select Peak Current by pushing the selector button to cycle through to illuminate the Peak Current Icon

3. Turn the Adjustment Knob to set the Peak Current at 100A (Range is 10-200 Amps)



4. Select the Base Current by pushing the selector key to cycle through to illuminate the Base Current Icon

5. Turn the Adjustment Knob to set the Base Current at 30A (Range is 10-200 Amps)



6. Select the Pulse width ( % on time of the Peak Amp) by pushing the selector key to cycle through to illuminate the % Pulse Icon

7. Turn the Adjustment Knob to set the Pulse Width at 60%. (Range is 10 - 90%).



8. Select the Pulse Frequency by pushing the selector key to cycle through to illuminate the Pulse Hz Icon

9. Turn the Adjustment Knob to set the Pulse Hz to 2 Hz (Range is 0.5 - 200Hz)



## TIG Welding Set and Operation

- (1) Connect the **TIG Torch** connector to the **negative terminal** and tighten it
- (2) Connect the torch switch remote lead into the torch remote socket
- (3) Insert the torch gas connector into the quick lock gas receptacle
- (4) Connect the **Earth Cable** connector into the **positive terminal** and tighten it
- (5) (A) Connect gas line to Gas Regulator and connect the gas regulator to the Gas Cylinder  
(B) Connect the gas line to the quick lock gas inlet connector at the rear of the machine  
(C) Slowly open the cylinder valve.  
(D) Set the flow rate on the regulator to approximately 8 -12 l/min.  
(E) Close the cylinder valve and pay attention to the needle indicator of the contents pressure gauge on the regulator, if the needle drops away towards zero there is a gas leak. Sometimes a gas leak can be slow and to identify it will require leaving the gas pressure in the regulator and line for an extended time period. In this situation it is recommended to open the cylinder valve, set the flow rate to 8 -12 l/min, close the cylinder valve and check after a minimum of 15 minutes.  
(F) If there is a gas loss then check all connectors and clamps for leakage by brushing or spraying with soapy water, bubbles will appear at the leakage point.  
(G) Tighten clamps or fittings to eliminate gas leakage. **Important:** We strongly recommend that you check for gas leakage prior to operation of your machine. We recommend that you close the cylinder valve when the machine is not in use.
- (6) Turn on the machine using the **ON/OFF** switch
- (7) Select the preferred **TIG** function with the **MODE** selector switch



AC (alternating current) enables us to TIG weld non ferrous alloys like Aluminium, Aluminium Alloys and Magnesium. These materials have an insulating surface oxide layer that melts at a higher temperature than the base metal making it difficult to weld the base metal if the oxides are not removed. AC welding current is ideal because the nature of the AC wave form assists in breaking the surface oxide layer. HF arc ignition provides easy and precise starting of the arc.

- (8) Assemble the front end torch parts use the correct size and type of tungsten electrode for the job.
- (9) Select AC tig function using the mode selection key
- (10) Choose **2T** or **4T** trigger function preferred as per the descriptions below
  - 2T** Selection provides 2 times function of the torch switch.
    - (1) Pressing the torch switch gives arc ignition and initializes the welding current and the welding current is maintained by the torch remaining on.
    - (2) Releasing the torch switch stops the welding by introducing down slope and the current falls to minimum level and then terminates the welding current and introduces the post flow gas.
  - 4T** Selection provides 4 times function of the torch switch
    - (1) Pressing the torch switch gives arc ignition and initializes the welding current
    - (2) Releasing the torch switch continues the welding operation.
    - (3) Pressing the torch switch and holding introduces down slope and current falls to minimum current.
    - (4) Releasing the torch switch terminates the welding operation and introduces the post flow gas.
- (11) Choose the preferred welding current (amperage) to suit the tungsten size material type and thickness to be welded.
- (12) Set the AC Balance control to approximately 20%
- (13) Set the AC Hz control to approximately 60Hz
- (14) Lay the outside edge of the Gas Cup on the work piece with the Tungsten Electrode 1- 3mm from the work piece this method will provide a clean positive arc ignition.
- (15) Press the torch switch and the arc will ignite across the gap between the tungsten and work piece. Hold even distance of about 2mm gap between the tungsten and work piece to maintain the arc.
- (16) Release the torch switch to bring in the end of the welding sequence dependant of 2T or 4T trigger function choice.

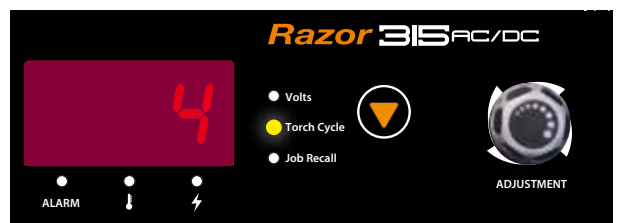
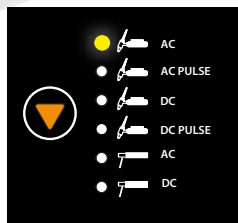

(8) Assemble the front end torch parts use the correct size and type of tungsten electrode for the job, the tungsten electrode requires a sharpened point for DC welding

(9) Select **AC** TIG Function. Push the  key until the **AC Tig** icon illuminates

(10) Select **2** or **4** trigger function as required by the pushing the  key until the Torch Cycle icon illuminates. Turn the Adjustment knob to select the option shown on the digital display. Press the torch switch to exit Torch Cycle mode. The display will default to the set welding current, adjust the set current using the Adjustment knob.

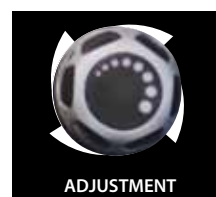
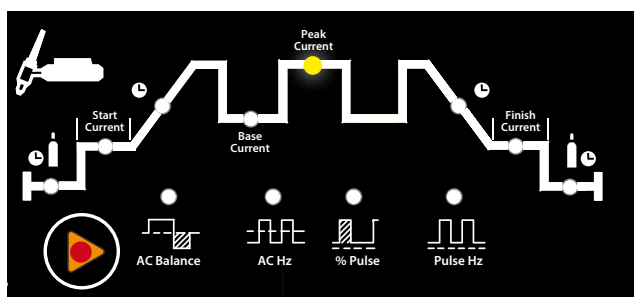

(11) **Current Set.** Select by pushing selector key to cycle through to illuminate the Peak Current icon. Set the Peak Current (amps) to suit the tungsten size material type and thickness to be welded.

Turn the Adjustment Knob to set the Peak Current value. (Range is 20-320A)

The value selected shows on the digital display. It is the maximum set value of amperage the machine will deliver..

# AC TIG Welding - AC Wave Balance Control

AC (alternating current) enables us to TIG weld non ferrous alloys like Aluminium, Magnesium and Aluminium Alloys. These materials have an insulating surface oxide layer that melts at a higher temperature than the base metal making it difficult to weld the base metal if the oxides are not removed. AC welding current is ideal because the nature of the AC wave form assists in breaking the surface oxide layer.

AC (alternating current) has a current cycle that flows from + (direct) polarity to - (reverse) polarity. The reversing of the polarity breaks the surface oxide while the direct polarity melts the base material.

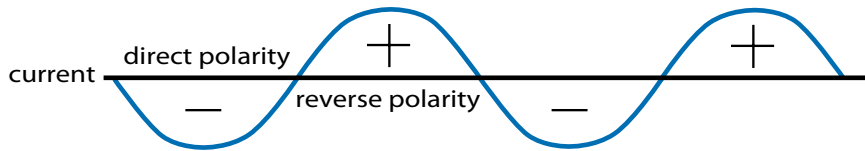

There are inherent problems that come with AC TIG arc rectification, arc stutter, arc wandering and arc stoppage. These problems typically occur during the transition between + and - cycles. The current is less (30%) during the half of the cycle when the electrode is positive and there is a resistance of the electron flow during this half cycle (rectification). The lack of current flow during this half cycle makes the AC arc unstable.

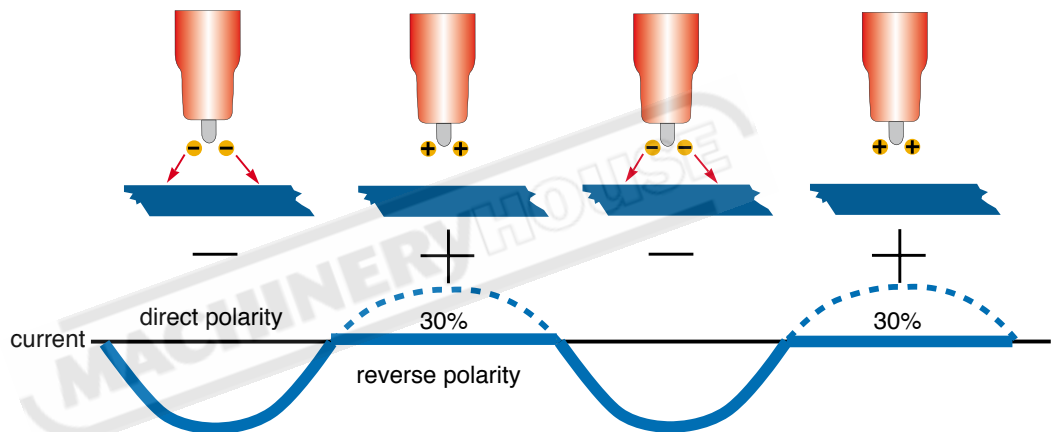

To overcome this lack of flow during one half of the cycle, a high-frequency (HF) voltage is generated and fed into the welding circuit. The HF maintains the arc stability during the half cycle when the electrode is positive.

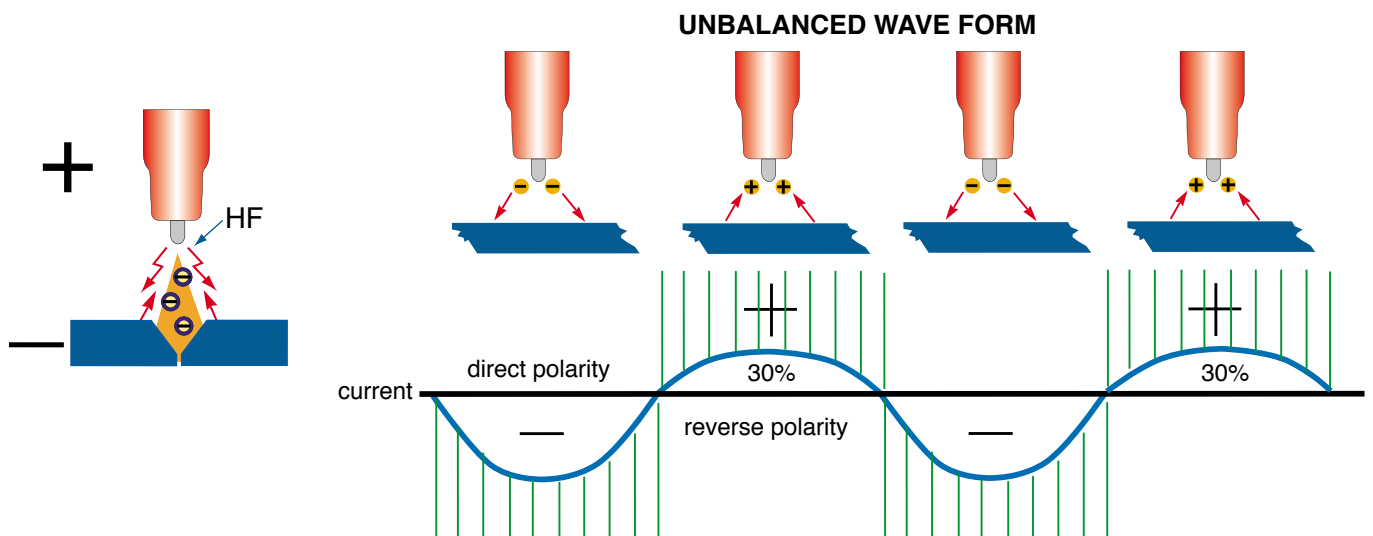

High-frequency voltage flows continually in the welding circuit and keeps the shielding arc in the welding area in an ionized state. When the arc is ionized the arc is maintained during the half of the cycle when the electrode is positive. However while the arc is maintained less current flows during this half of the AC cycle, producing an unbalanced wave.

# AC TIG Welding - AC Wave Balance Control

In older machines, a balanced current output wave was achieved using a large number of capacitors in series or a battery in the welding circuit. Modern TIG power sources use electronics to create and maintain a balanced wave and now most AC TIG power sources produce a square wave current output.

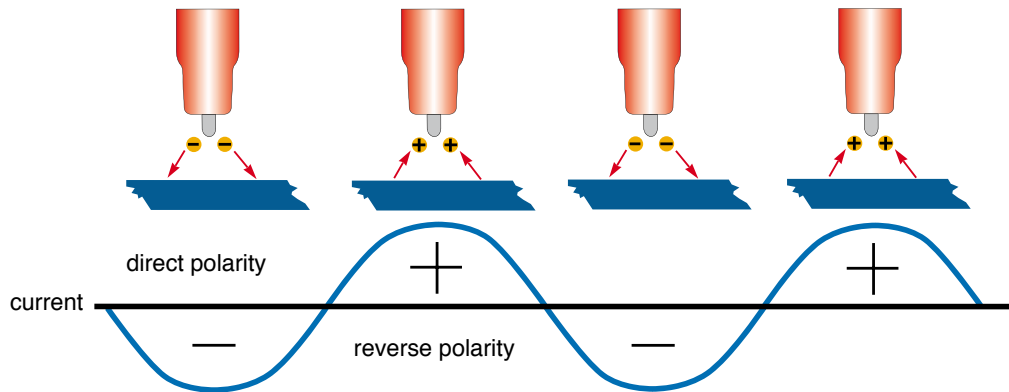

A square wave power supply can change the current from electrode + positive to electrode - negative very quickly. This produces high voltage as the current switches polarities allowing the arc to restart easily. The arc can be maintained without the use of high-frequency or any other arc stabilising methods.

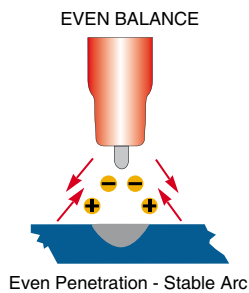

## BALANCED SQUARE WAVE FORM

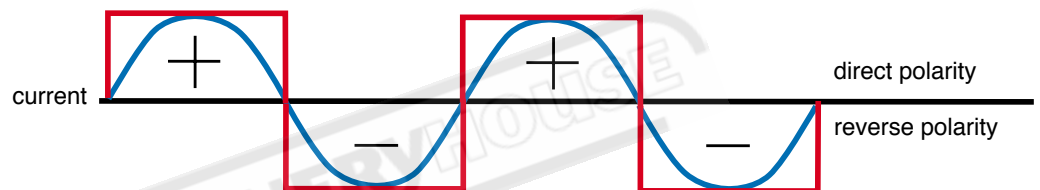

The output current and voltage are controlled electronically so the amount of current electrode positive and the amount of current electrode negative can be adjusted. This allows the welder to adjust the amount of cleaning and the amount of penetration. This is achieved electronically by adjusting the balance control dial on the welding machine. More current flow from the + direct polarity produces stronger arc energy and current flow from the tungsten and is good for removing the oxidized surface of the work piece. However too much + current flow can drive too much energy to the tungsten causing it to overheat and melt the tungsten electrode.

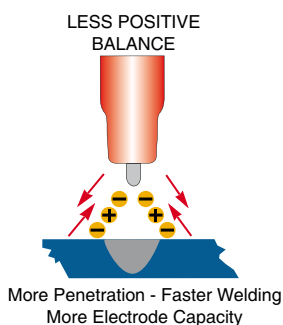

## Balance Adjusted for More Penetration - Cooler Tungsten

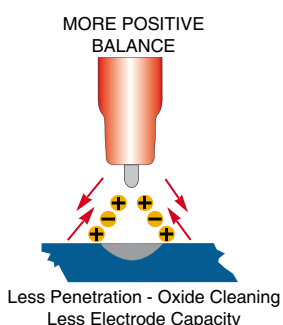
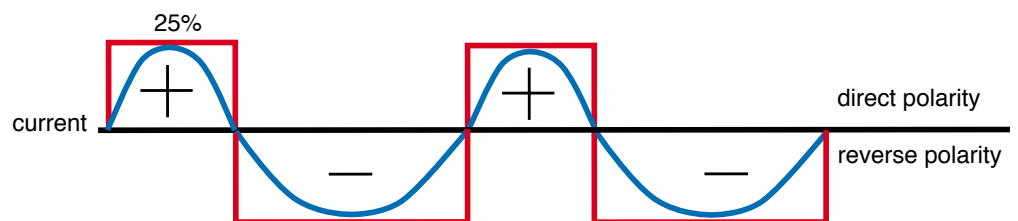

## Balance Adjusted for More Oxide Cleansing Action - Hotter Tungsten

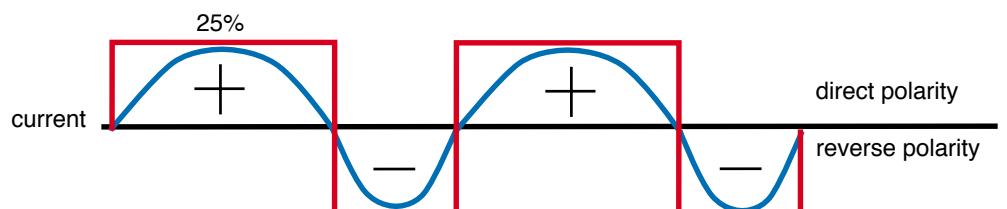

# Set up and operation for AC PULSE TIG Welding

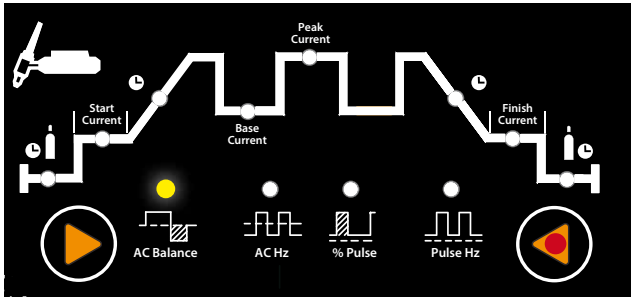

(12) Select the AC Balance Control by pushing selector key to cycle through to illuminate the AC Balance icon.

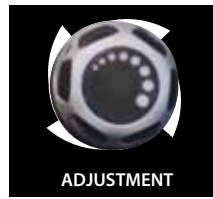

Turn the Adjustment Knob to set the AC Balance (Range is 10-60 %).



Set the value at 20. It is the % of time that the current flow remains at electrode negative during each AC cycle. (See pages for 31-32-34 for more AC Balance information)

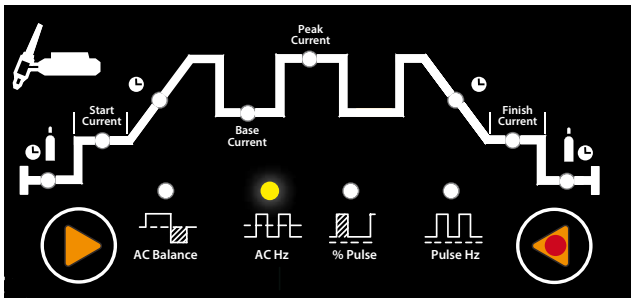

(13) Select the AC Hz Control by pushing selector key to cycle through to illuminate the AC Hz icon.



Turn the Adjustment Knob to set the AC Hz (Range is 20-70).



Set the value at 60. The value selected is how many times per second the AC wave completes a full cycle.



(14) Lay the outside edge of the Gas Cup on the work piece with the Tungsten Electrode 1- 3mm from the work piece



(15) Press the torch switch and the arc will ignite across the gap between the tungsten and work piece. Hold even distance of about 2mm gap between the tungsten and work piece to maintain the arc.



(16) Release the torch switch to bring in the end of the welding sequence dependant of 2T or 4T trigger function choice

# Set up and operation for AC PULSE TIG Welding

The Razorweld 315ACDC machine has digital pulse frequency control. All the parameters for AC & DC Pulse TIG welding - Peak Amp, Base Amp, Pulse Frequency and Pulse Width are easy to set via the digital control panel.

## EXAMPLE OF PULSE AC TIG WELDING - SETUP PARAMETERS:

**Material = Aluminium x 3.0mm / Tungsten Electrode = 2.4mm Zirconiated / Gas = Argon**

- (1) Prepare the machine for AC TIG welding as per the AC TIG operating guide on page
  - (2) Set the **Peak Current** at 150 Amps
  - (3) Set the **Base Current** around 40% (Base Current is % of the Peak Current eg 40% of 150 = 60 Amps)
  - (4) Set the **Pulse Frequency** around 2Hz (pulses per second)
  - (5) Set the **Pulse Width** around 60% (the current will spend 60% at Peak Current & 40% at Base Current)
- You can experiment by changing any of the variables to see what effect it has over the welding and what the end result can be, but it is suggested to change only one variable at a time and then check the welding result.

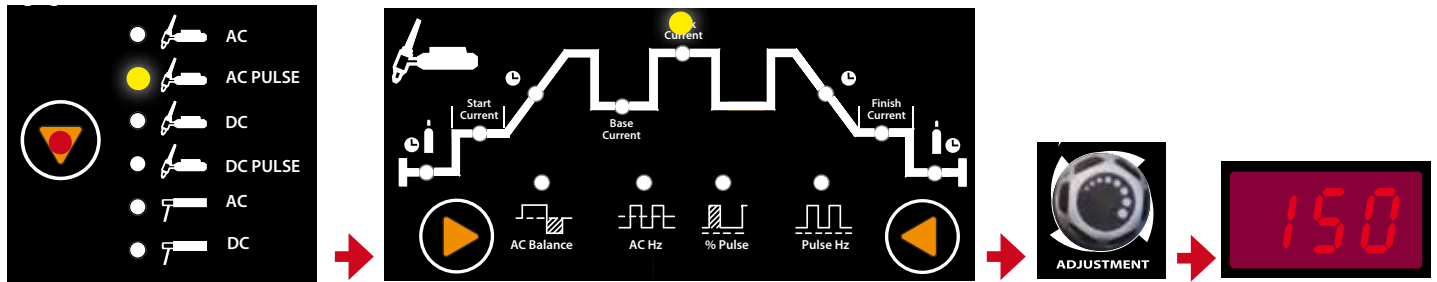

1. Select AC Pulse by pushing selector key to cycle through to illuminate AC Pulse icon.
2. Select Peak Current by pushing the selector button to cycle through to illuminate the Peak Current Icon
3. Turn the Adjustment Knob to set the Peak Current at 150A (Range is 20-3200 Amps)

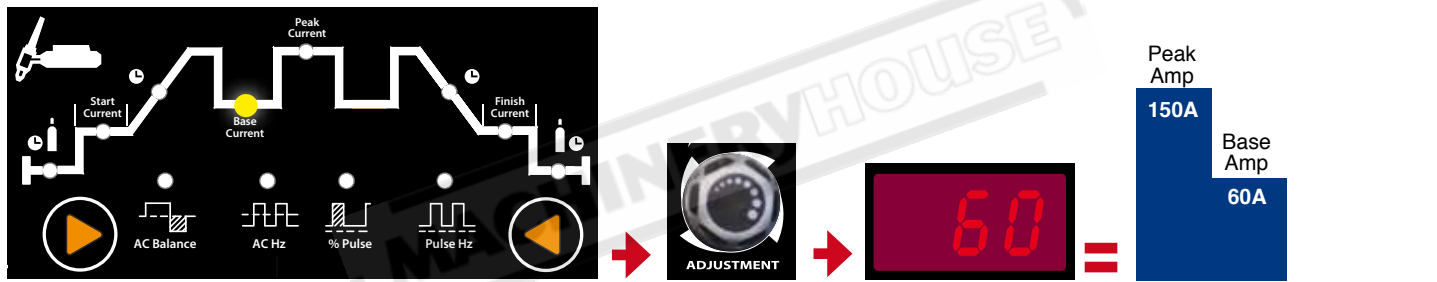

4. Select the Base Current by pushing the selector key to cycle through to illuminate the Base Current Icon
5. Turn the Adjustment Knob to set the Base Current at 60A (Range is 30-320 Amps)



6. Select the Pulse width ( % on time of the Peak Amp) by pushing the selector key to cycle through to illuminate the % Pulse Icon
7. Turn the Adjustment Knob to set the Pulse Width at 60%. (Range is 10 - 90%).



8. Select the Pulse Frequency by pushing the selector key to cycle through to illuminate the Pulse Hz Icon
9. Turn the Adjustment Knob to set the Pulse Hz to 2 Hz (Range is 0.5 - 5.0Hz)



## AC TIG Welding - AC Wave Balance Control

It is possible with the RAZOR200ACDC machine to adjust the frequency of the AC Square Wave output. It means that the amount of time that it takes the AC square wave to complete a full cycle switch from positive (+) to negative (-) can be adjusted from 20 Hz (20 times per second) to 70 Hz

Increasing frequency (Hz) causes the current to change direction more often, which means that it spends less time per cycle in both DC electrode negative and DC electrode positive mode. By spending less time at each polarity, the arc cone has less time to expand.

A higher frequency produces a narrower arc cone producing an arc that is tighter with more focus at the exact spot the electrode is pointing. The result is improved arc stability, ideal for fillet welds and other fit ups requiring precise penetration.

Decreasing the frequency softens the arc and broadens the weld pool producing a wider bead, produces good overall penetration and ideal for build up applications.

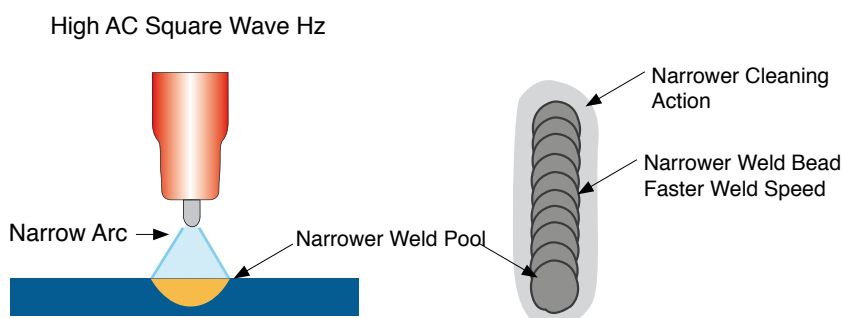
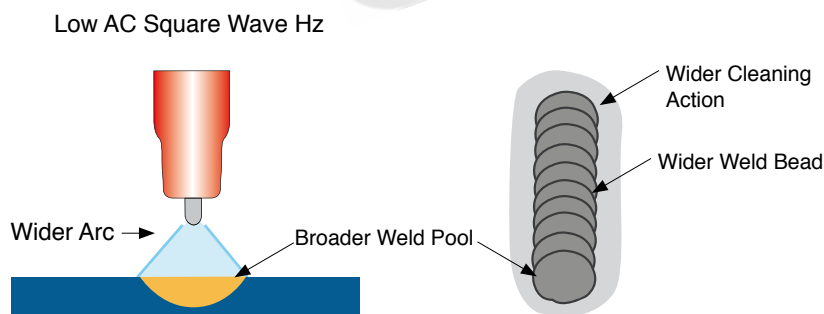
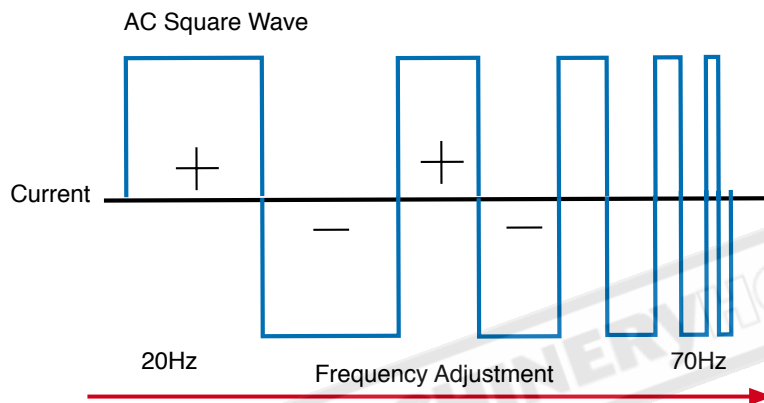

# Remote Amperage Controls

Remote amperage controls allow for the welding current to adjusted remotely from the welding machine during welding.

## Remote Foot Amp Control Connection



Connect the remote control 2 pin and 5 pin plugs from the Remote Foot Control leads to the corresponding remote receptacles on the front panel of the machine.

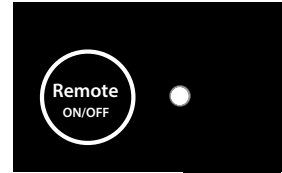

(3) Activate the remote control.

1. No LED Remote is OFF
2. Press button once LED Light is Solid and ready to activate
3. Press button twice and LED Light is Flashing Remote control is activated

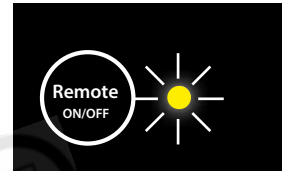

## Remote Hand Amp Control Connection

Type: ER1MS-H

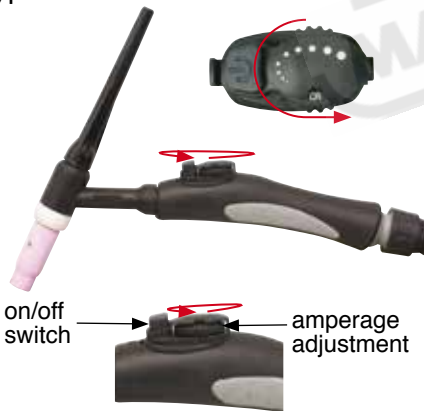

Connect the remote control 7 pin plug from the TIG Torch switch lead to the 7 pin remote receptacle on the front panel of the machine.

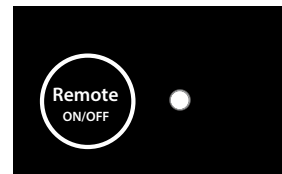

(3) Activate the remote control.

1. No LED Remote is OFF
2. Press button once LED Light is Solid and ready to activate
3. Press button twice and LED Light is Flashing Remote control is activated

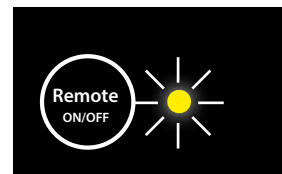

### NOTE:

**DO NOT** connect both remote controls at the same time, this will cause settings to be inconsistent when both remote's are connected.

# Tungsten Electrodes

Tungsten is a rare metallic element used for manufacturing TIG welding electrodes. The TIG process relies on tungsten's hardness and high-temperature resistance to carry the welding current to the arc. Tungsten has the highest melting point of any metal, 3,410 degrees Celsius.

Tungsten electrodes are nonconsumable and come in a variety of sizes, they are made from pure tungsten or an alloy of tungsten and other rare earth elements. Choosing the correct tungsten depends on the material being welded, the amount of amps required and whether you are using AC or DC welding current.

Tungsten electrodes are colour-coded at the end for easy identification.

Below are the most commonly used tungsten electrodes found in the New Zealand and Australian market.

## Thoriated

Thoriated tungsten electrodes (AWS classification EWTh-2) contain a minimum of 97.30 percent tungsten and 1.70 to 2.20 percent thorium and are called 2 percent thoriated. They are the most commonly used electrodes today and are preferred for their longevity and ease of use. Thorium increases the electron emission qualities of the electrode, which improves arc starts and allows for a higher current-carrying capacity. This electrode operates far below its melting temperature, which results in a considerably lower rate of consumption and eliminates arc wandering for greater stability. Compared with other electrodes, thoriated electrodes deposit less tungsten into the weld puddle, so they cause less weld contamination.

Thorium however is a low-level radioactive hazard and many users have switched to other alternatives. Regarding the radioactivity, thorium is an alpha emitter but when it is enclosed in a tungsten matrix the risks are negligible. Thus holding a stick of Thoriated tungsten in your hand should not pose a great threat unless a welder has open cuts on their skin. Thoriated tungsten should not get in contact with open cuts or wounds. The more significant danger to welders can occur when thorium oxide gets into the lungs. This can happen from the exposure to vapours during welding or from ingestion of material/dust in the grinding of the tungsten. Follow the manufacturer's warnings, instructions, and the Material Safety Data Sheet (MSDS) for its use.

## Ceriated (Color Code: Orange)

Ceriated tungsten electrodes (AWS classification EWCe-2) contain a minimum of 97.30 percent tungsten and 1.80 to 2.20 percent cerium and are referred to as 2 percent ceriated. Ceriated tungstens perform best in DC welding at low current settings. They have excellent arc starts at low amperages and become popular in such applications as orbital tube welding, thin sheet metal work. They are best used to weld carbon steel, stainless steel, nickel alloys, and titanium, and in some cases it can replace 2 percent thoriated electrodes. Ceriated tungsten is best suited for lower amperages it should last longer than Thoriated tungsten higher amperage applications are best left to Thoriated or Lanthanated tungsten.

## Lanthanated (Color Code: Gold)

Lanthanated tungsten electrodes (AWS classification EWL-1.5) contain a minimum of 97.80 percent tungsten and 1.30 percent to 1.70 percent lanthanum, and are known as 1.5 percent lanthanated. These electrodes have excellent arc starting, a low burn off rate, good arc stability, and excellent re-ignition characteristics. Lanthanated tungstens also share the conductivity characteristics of 2 percent thoriated tungsten. Lanthanated tungsten electrodes are ideal if you want to optimise your welding capabilities. They work well on AC or DC electrode negative with a pointed end, or they can be balled for use with AC sine wave power sources. Lanthanated tungsten maintains a sharpened point well, which is an advantage for welding steel and stainless steel on DC or AC from square wave power sources.

## Zirconiated (Color Code: White)

Zirconiated tungsten electrodes (AWS classification EWZr-1) contain a minimum of 99.10 percent tungsten and 0.15 to 0.40 percent zirconium. Most commonly used for AC welding Zirconiated tungsten produces a very stable arc and is resistant to tungsten spitting. It is ideal for AC welding because it retains a balled tip and has a high resistance to contamination. Its current-carrying capacity is equal to or greater than that of thoriated tungsten. Zirconiated tungsten is not recommended for DC welding.

## Tungsten Electrodes Rating for Welding Currents

Tungsten Diameter mm	DC Current Amps Torch Negative 2% Thoriated	AC Current Amps Un-Balanced Wave 0.8% Zirconiated	AC Current Amps Balanced Wave 0.8% Zirconiated
1.0mm	15 - 80	15 - 80	20 - 60
1.6mm	70 - 150	70 - 150	60 - 120
2.4mm	150 - 250	140 - 235	100 - 180
3.2mm	250 - 400	225 - 325	160 - 250
4.0mm	400 - 500	300 - 400	200 - 320

# Tungsten Preparation

Always use **DIAMOND** wheels when grinding and cutting. While tungsten is a very hard material, the surface of a diamond wheel is harder, and this makes for smooth grinding. Grinding without diamond wheels, such as aluminium oxide wheels, can lead to jagged edges, imperfections, or poor surface finishes not visible to the eye that will contribute to weld inconsistency and weld defects.

Always ensure to grind the tungsten in a longitudinal direction on the grinding wheel. Tungsten electrodes are manufactured with the molecular structure of the grain running lengthwise and thus grinding crosswise is “grinding against the grain.” If electrodes are ground crosswise, the electrons have to jump across the grinding marks and the arc can start before the tip and wander. Grinding longitudinally with the grain, the electrons flow steadily and easily to the end of the tungsten tip. The arc starts straight and remains narrow, concentrated, and stable.

grind longitudinal on the grinding wheel

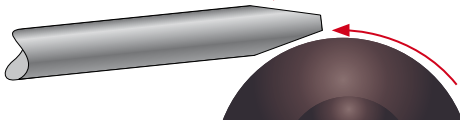

don't grind across the grinding wheel

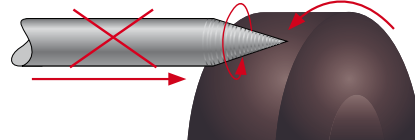

## Electrode Tip/Flat

The shape of the tungsten electrode tip is an important process variable in precision arc welding. A good selection of tip/flat size will balance the need for several advantages. The bigger the flat, the more likely arc wander will occur and the more difficult it will be to arc start. However, increasing the flat to the maximum level that still allows arc start and eliminates arc wander will improve the weld penetration and increase the electrode life. Some welders still grind electrodes to a sharp point, which makes arc starting easier. However, they risk decreased welding performance from melting at the tip and the possibility of the point falling off into the weld pool.

2.5 times tungsten diameter

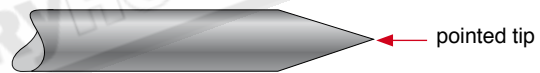
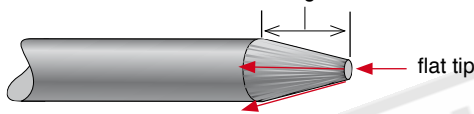

## Electrode Included Angle/Taper - DC Welding

Tungsten electrodes for DC welding should be ground longitudinally and concentrically with diamond wheels to a specific included angle in conjunction with the tip/flat preparation. Different angles produce different arc shapes and offer different weld penetration capabilities. In general, blunter electrodes that have a larger included angle provide the following benefits:

- Last Longer
- Have better weld penetration
- Have a narrower arc shape
- Can handle more amperage without eroding.

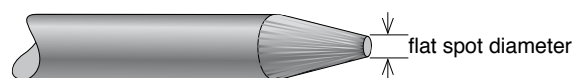

Sharper electrodes with smaller included angle provide:

- Offer less arc weld
- Have a wider arc
- Have a more consistent arc



The included angle determines weld bead shape and size. Generally, as the included angle increases, penetration increases and bead width decreases.

Tungsten Diameter	Diameter at the Tip - mm	Constant Included Angle - Degrees	Current Range Amps	Current Range Pulsed Amps
1.0mm	.250	20	05 - 30	05 - 60
1.6mm	.500	25	08 - 50	05 - 100
1.6mm	.800	30	10 - 70	10 - 140
2.4mm	.800	35	12 - 90	12 - 180
2.4mm	1.100	45	15 - 150	15 - 250
3.2mm	1.100	60	20 - 200	20 - 300
3.2mm	1.500	90	25 - 250	25 - 350

# Suregrip Series SR26 ERGO TIG TORCH



## 180A AIR COOLED TIG WELDING TORCH

Rating: 180Amp DC, 125Amp AC @35% duty cycle.

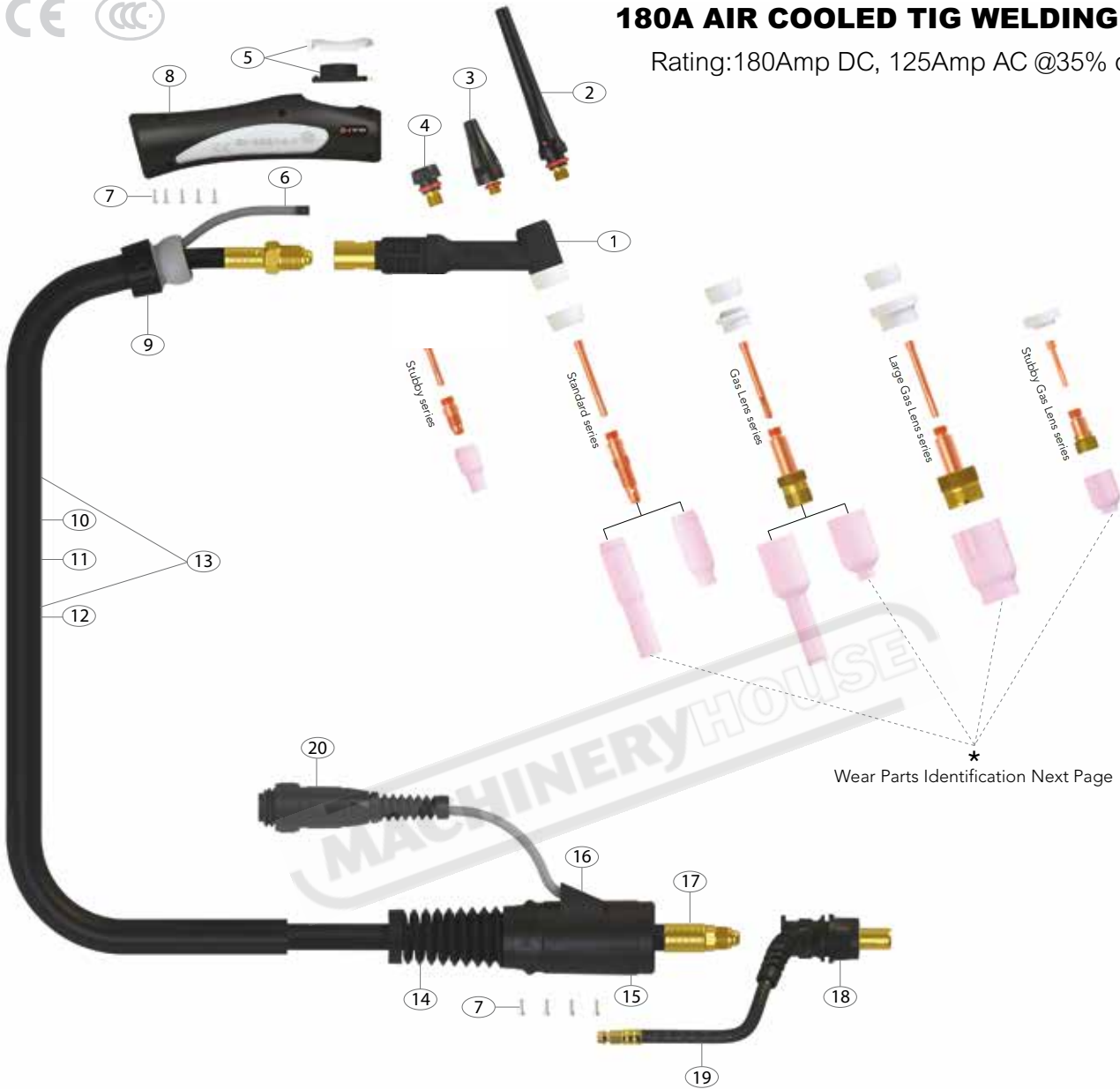

\*  
Wear Parts Identification Next Page

### Torch Model

#### Description

#### Part Number

4m

8m

SR26 Suregrip Tig Torch Package c/w QF Gas Connect

SR-26-4MCP50

SR-26-8MCP50

### Spare Parts

Part Number	Description	Part Number	Description
1	WP26 Torch head	12	UERNCL-32 Neoprene Cover X 3.2mt
	WP26F Torch head flexible		UERNCL-72 Neoprene Cover X 7.2mt
2	57Y02 Back cap long	13	UERCO200-40 Sheath X 12.5ft Inc Leather Cover
3	57Y03 Medium back cap		UERCO200-80 Sheath X 25ft Inc Leather Cover
4	57Y04 Short back cap	14	USLH26-S Cable Support Large
5	UER1MS Momentary Kit	15	USLH26-H "Surelok" Housing Large
6	UERSWL4 Trigger Lead 12.5ft	16	USLH26-C "Surelok" Housing Cover
	UERSWL8 Trigger Lead 25ft	17	USL46V28AR Power Cable X 12.5ft "Surelok" Rubber
7	UERSP1 Screw Pack		USL46V30AR Power Cable X 25ft "Surelok" Rubber
8	UERH200 Large Ergo Tig Handle	18	USL3550 "Surelok" Body & Support
9	UERKJ200 Large Knuckle Joint	19	USL-1-GS4 Gas Supply Hose
10	UERLC200-08 Leather Cover X 0.8mt	20	10004667 7 Pin Plug
11	UERJK200 Joining Repair Kit		





# TIG WELDING TROUBLE SHOOTING

The following chart addresses some of the common problems of TIG welding. In all cases of equipment malfunction, the manufacturer's recommendations should be strictly adhered to and followed.

<b>1: Tungsten burning away quickly</b>	
Possible Reason	Suggested Remedy
Incorrect Gas	Check that pure Argon is being used
No gas	Check the gas cylinder contains gas and is connected
Inadequate gas flow	Check the gas is connected, check hoses, gas valve and torch are not restricted. Set the gas flow between 10 - 15 l/min flow rate
Back cap not fitted correctly	Make sure the torch back cap is fitted so that the o-ring is inside the torch body
Torch connected to DC +	Connect the torch to the DC- output terminal
Incorrect tungsten being used	Check and change the tungsten type if necessary
Tungsten being oxidised after weld is finished	Keep shielding gas flowing 10–15 seconds after arc stoppage. 1 second for each 10 amps of weld current.
Tungsten melting back into the nozzle on AC welding	Check that correct type of tungsten is being used. Check the balance control is not set too high on the balance - reduce to a lower setting
<b>2: Contaminated tungsten</b>	
Possible Reason	Suggested Remedy
Touching tungsten into the weld pool	Keep tungsten from contacting weld puddle. Raise the torch so that the tungsten is off of the work piece 2 - 5mm
Touching the filler wire to the tungsten	Keep the filler wire from touching the tungsten during welding, feed the filler wire into the leading edge of the weld pool in front of the tungsten
Tungsten melting into the weld pool	Check that correct type of tungsten is being used. Too much current for the tungsten size so reduce the amps or change to a larger tungsten
<b>3: Porosity - poor weld appearance and colour</b>	
Possible Reason	Suggested Remedy
Incorrect Gas	Check that pure Argon is being used
Inadequate gas flow / gas leaks	Check the gas is connected, check hoses, gas valve and torch are not restricted. Set the gas flow between 10 - 15 l/min flow rate. Check hoses and fittings for holes, leaks etc.,
Moisture on the base metal	Remove all moisture from base metal before welding
Contaminated base metal	Remove materials like paint, grease, oil, and dirt, including mill scale from base metal
Contaminated filler wire	Remove all grease, oil, or moisture from filler metal.
Incorrect filler wire	Check the filler wire and change if necessary
<b>4: Yellowish residue / smoke on the alumina nozzle &amp; discoloured tungsten</b>	
Possible Reason	Suggested Remedy
Incorrect Gas	Use pure Argon gas
Inadequate gas flow	Set the gas flow between 10 - 15 l/min flow rate
Inadequate post flow gas	Increase the post flow gas time
Alumina gas nozzle too small for size of tungsten being used	Increase the size of the alumina gas nozzle
<b>5: Unstable Arc during DC welding</b>	
Possible Reason	Suggested Remedy
Torch connected to DC +	Connect the torch to the DC- output terminal
Contaminated base metal	Remove materials like paint, grease, oil, and dirt, including mill scale from base metal.
Tungsten is contaminated	Remove 10mm of contaminated tungsten and re grind the tungsten
Arc length too long	Lower torch so that the tungsten is off of the work piece 2 - 5mm
<b>6: HF present but no welding power</b>	
Possible Reason	Suggested Remedy
Incomplete welding circuit	Check earth lead is connected. Check all cable connections. If using a water cooled torch check that the power cable is not separated.
No gas	Check the gas is connected and cylinder valve open, check hoses, gas valve and torch are not restricted. Set the gas flow between 10 - 15 l/min flow rate
Tungsten melting into the weld pool	Check that correct type of tungsten is being used. Too much current for the tungsten size so reduce the amps or change to a larger tungsten

## continued- TIG WELDING TROUBLE SHOOTING

<b>7: Arc wanders during DC welding</b>	
<b>Possible Reason</b>	<b>Suggested Remedy</b>
Poor gas flow	Check and set the gas flow between 10 - 15 l/min flow rate
Incorrect arc length	Lower torch so that the tungsten is off of the work piece 2 - 5mm
Tungsten incorrect or in poor condition	Check that correct type of tungsten is being used. Remove 10mm from the weld end of the tungsten and re sharpen the tungsten
Poorly prepared tungsten	Grind marks should run lengthwise with tungsten, not circular. Use proper grinding method and wheel.
Contaminated base metal	Remove contaminating materials like paint, grease, oil, and dirt, including mill scale from base metal.
Contaminated filler wire	Remove all grease, oil, or moisture from filler metal.
Incorrect filler wire	Check the filler wire and change if necessary
<b>8: Arc difficult to start or will not start DC welding</b>	
<b>Possible Reason</b>	<b>Suggested Remedy</b>
Incorrect machine set up	Check machine set up is correct
No gas, incorrect gas flow	Check the gas is connected and cylinder valve open, check hoses, gas valve and torch are not restricted. Set the gas flow between 10 - 15 l/min flow rate
Tungsten is contaminated	Remove 10mm of contaminated tungsten and re grind the tungsten
Incorrect tungsten size and or tungsten being used	Check and change the size and or the tungsten if required
Loose connection	Check all connectors and tighten
Earth clamp not connected to work	Connect the earth clamp directly to the work piece wherever possible
Loss of high frequency	Check torch and cables for cracked insulation or bad connections. Check spark gaps and adjust if necessary

## MMA (Stick) WELDING TROUBLE SHOOTING

The following chart addresses some of the common problems of MMA welding. In all cases of equipment malfunction, the manufacturer's recommendations should be strictly adhered to and followed.

<b>1: No arc</b>	
Possible Reason	Suggested Remedy
Incomplete welding circuit	Check earth lead is connected. Check all cable connections.
Wrong mode selected	Check the MMA selector switch is selected
No power supply	Check that the machine is switched on and has a power supply
<b>2: Porosity – small cavities or holes resulting from gas pockets in weld metal.</b>	
Possible Reason	Suggested Remedy
Arc length too long	Shorten the arc length
Work piece dirty, contaminated or moisture	Remove moisture and materials like paint, grease, oil, and dirt, including mill scale from base metal
Damp electrodes	Use only dry electrodes
<b>3: Excessive Spatter</b>	
Possible Reason	Suggested Remedy
Amperage too high	Decrease the amperage or choose a larger electrode
Arc length too long	Shorten the arc length
<b>3: Weld sits on top, lack of fusion</b>	
Possible Reason	Suggested Remedy
Insufficient heat input	Increase the amperage or choose a larger electrode
Work piece dirty, contaminated or moisture	Remove moisture and materials like paint, grease, oil, and dirt, including mill scale from base metal
Poor welding technique	Use the correct welding technique or seek assistance for the correct technique
<b>4: Lack of penetration</b>	
Possible Reason	Suggested Remedy
Insufficient heat input	Increase the amperage or choose a larger electrode
Poor welding technique	Use the correct welding technique or seek assistance for the correct technique
Poor joint preparation	Check the joint design and fit up, make sure the material is not too thick. Seek assistance for the correct joint design and fit up
<b>5: Excessive penetration - burn through</b>	
Possible Reason	Suggested Remedy
Excessive heat input	Reduce the amperage or use a smaller electrode
Incorrect travel speed	Try increasing the weld travel speed
<b>6: Uneven weld appearance</b>	
Possible Reason	Suggested Remedy
Unsteady hand, wavering hand	Use two hands where possible to steady up, practise your technique
<b>7: Distortion – movement of base metal during welding</b>	
Possible Reason	Suggested Remedy
Excessive heat input	Reduce the amperage or use a smaller electrode
Poor welding technique	Use the correct welding technique or seek assistance for the correct technique
Poor joint preparation and or joint design	Check the joint design and fit up, make sure the material is not too thick. Seek assistance for the correct joint design and fit up
<b>7: Electrode welds with different or unusual arc characteristic</b>	
Possible Reason	Suggested Remedy
Incorrect polarity	Change the polarity, check the electrode manufacturer for correct polarity

Welding Guns Of Australia Pty Ltd ('Us', 'We') warrants that the following products under UNI-MIG, UNI-TIG, UNI-PLAS, UNI-FLAME, TECNA, T&R, HIT-8SS & ROTA, supplied by Us and purchased by you from an Authorised UNI-MIG, UNI-TIG, UNI-PLAS, UNI-FLAME, TECNA, T&R, HIT-8SS & ROTA Dealer throughout Australia are free of Material and Faulty Workmanship defects except for those products listed under 'Warranty Exclusions'.

These terms and conditions supersede and exclude all former and other representations and arrangements relating to any warranties on these products.

## WARRANTY PERIOD

We offer the following 'Warranty Periods' from 'date of purchase':  
 An Extended Warranty Period of 6 months total shall apply only to Machinery where offered and warranty is registered online.

### UNI-MIG WELDING MACHINES

UNI-MIG DIY Series (Power Source Only)	2 Years	(Clause 3)
RAZORWELD Series (Power Source Only)	3 Years	(Clause 1&3)
UNI-MIG Procraft Series (Power Source Only)	3 Years	(Clause 1&3)
UNI-MIG Trade Series (Power Source Only)	3 Years	(Clause 1&3)
UNI-MIG Trade Series SWF (Power Source / Seperate Wire Feeder Only)	3 Years	(Clause 1&3))
UNI-MIG Workshop Series (Power Source Only)	3 Years	(Clause 1&3)
UNI-MIG Workshop Series SWF (Power Source / Separate Wire Feeder Only)	3 Years	(Clause 1&3)
UNI-MIG Jasic Inverter MIG (Power Source Only)	3 Years	(Clause 3)
UNI-MIG Jasic Inverter MIG SWF (Power Source / Separate Wire Feeder Only)	3 Years	(Clause 3)
UNI-TIG Jasic Inverter TIG (Power Source Only)	3 Years	(Clause 3)
UNI-MIG Water Cooler	1 Year	(Clause 3)
T&R Pulse MIG (Power Source Only)	2 Year	(Clause 3)
T&R Pulse MIG SWF (Power Source / Separate Wire Feeder Only)	2 Year	(Clause 3)
UNI-PLAS (Power Source Only)	3 Years	(Clause 3)
UNI-PLAS Jasic Series (Power Source Only)	2 Years	(Clause 3)
UNI-PLAS Site Cut Series (Power Source Only)	1 Year	(Clause 3)
UNI-FLAME Gas Cutting and Welding Kits	3 Months	(Clause 2&3)
UNI-FLAME Straight Line & Gas Cutting Machines (Power Source Only)	1 Year	(Clause 3)
UNI-FLAME Regulators Argon/ Acetylene / Oxygen / LPG / Bobbin Flowmeter	1 Year	
UNI-FLAME Automatic Welding Helmet	2 Years	
UNI-MIG Automatic Welding Helmets	2 Years	
TECNA (Power Source Only)	1 Year	(Clause 3)
HIT-8SS Automatic Carriage (Power Source Only)	1 Year	(Clause 3)
ROTA 102 Rotating table	1 Year	
HOTBOX ElectrodeOven	1 Year	
SPOTCAR 3500	1 Year	(Clause 3)
TORCHES -GMAW, GTAW, MMAW, PLASMA, EARTH LEADS, INTERCONNECTING CABLES, GAS HOSE	3 Months	(Clause 3)

**(Clause 1)** 3 year warranty on transformers, inductor and rectifier. 1 year warranty on PCB, and all other components, .

**(Clause 2)** Gas Hose, Flashbacks are subject to and covered by the Manufacture's Individual Warranty, Contact the manufacturer for details

**(Clause 3)** This only Covers Manufactures defaults on all accesories for the first three months after date of purchase.

## WARRANTY / RETURNS / EXCHANGES

We understand that sometimes you may need to return a product you have purchased from Welding Guns Of Australia PTY LTD Authorised Dealer Network, to assist you, we have set out below the Welding Guns Of Australia PTY LTD Returns Policy that you should know.

Our Returns Policy includes the rights you have under the Australian Consumer Law and other relevant laws. Your Rights under the Australian Consumer Law - Our goods come with guarantees that cannot be excluded under the Australian Consumer Law. You are entitled to a replacement or refund for a major failure and for compensation for any other reasonably foreseeable loss or damage. You are also entitled to have the goods repaired or replaced if the goods fail to be of acceptable quality and the failure does not amount to a major failure.

- You shall inspect the Goods on delivery and shall within seven (7) days of delivery (time being of the essence) notify Welding Guns Of Australia PTY LTD of any alleged defect, shortage in quantity, damage or failure to comply with the description or quote.
- You shall also afford Welding Guns Of Australia PTY LTD the opportunity to inspect the Goods within a reasonable time following delivery if you believe the Goods are defective in any way.
- If you shall fail to comply with these provisions the Goods shall be presumed to be free from any defect or damage. For defective Goods, which Welding Guns Of Australia PTY LTD has agreed in writing that you are entitled to reject, Welding Guns Of Australia PTY LTD liability is limited to either (at the Welding Guns Of Australia PTY LTD discretion) replacing the Goods or repairing the Goods except where you have acquired Goods as a consumer within the meaning of the Trade Practices Act 1974 or the Fair Trading Acts of the relevant state or territories of Australia, and is therefore also entitled to, at the consumer's discretion either a refund of the purchase price of the Goods, or repair of the Goods, or replacement of the Goods.

Returns will only be accepted provided that:

- (a) You have complied with the provisions outlined above, and
  - (b) where the Goods are unable to be repaired, the Goods are returned at your cost within thirty (30) days of the delivery date, and
  - (c) Welding Guns Of Australia PTY LTD will not be liable for Goods which have not been stored or used in a proper manner, and
  - (d) the Goods are returned in the condition in which they were delivered and with all packaging material, brochures and instruction material in as new condition as is reasonably possible in the circumstances.
- Welding Guns Of Australia PTY LTD Accepts no responsibility for products lost, damaged or mislaid whilst in transit
  - Welding Guns Of Australia PTY LTD may (at their sole discretion) accept the return of Goods for credit but this may incur a handling fee of up to fifteen percent (15%) of the value of the returned Goods plus any freight costs.
  - Where a failure does not amount to a major failure, Welding Guns Of Australia PTY LTD is entitled to choose between providing you with a repair, replacement or other suitable remedy.
  - Your rights under the Australian Consumer Law are not limited by a defined time. However, the Australian Consumer Law does recognise that the relevant time period can vary from product to product, depending on factors such as the nature of the product and the price. Welding Guns Of Australia PTY LTD adopts the same approach. As you can appreciate, the type of remedy we can offer you may also vary depending on how long it takes you to return the product to us.

## MAKING A CLAIM

If you wish to make a claim under this Warranty, you should:

- Return the product to the point of purchase either in person or on a prepaid courier; or
- Contact Us by Telephone

Sydney Head Office: 02 9780 4200 or Mail PO Box 3033 Lansvale NSW 2166.

Queensland: 07 3333 2855

Victoria: 03 8682 9911

Western Australia: 08 6363 5111

When returned, the product must be accompanied with the original invoice including the purchase price and disclosing the purchase date

All costs of installation, cartage, freight, travelling expenses, hiring tools and insurance are paid by the Customer.

To the extent permitted by law, our total liability for loss or damage of every kind related to the product in any way whatsoever is limited to the amount paid to the retailer by you for the product or the value of the product.

No responsibility will be taken for products lost, damaged or mislaid whilst in transit.

# WARRANTY EXCLUSIONS

This Warranty covers Material and Faulty Workmanship defects only.

This Warranty does not cover damage caused by:

- Normal wear and tear due to usage
- Misuse or abusive use of the UNI-MIG, UNI-TIG, UNI-PLAS, UNI-FLAME, TECNA, T&R, HIT-8SS & ROTA, instructions supplied with the product.
- Failure to clean or improper cleaning of the product
- Failure to maintain the equipment such as regular services etc
- Incorrect voltage or non-authorized electrical connections
- Improper installation
- Use of non-authorized/non-standard parts
- Abnormal product performance caused by any ancillary equipment interference or other external factors
- Failure or any breakage caused by overload, dropping or abusive treatment or use by the customer
- Repair, modifications or other work carried out on the product other than by an Authorized UNI-MIG, UNI-TIG, UNI-PLAS, UNI-FLAME, TECNA, T&R, HIT-8SS & ROTA Service Dealer

Unless it is a manufacturing fault, this Warranty does not cover the following parts:

## **MIG Welding Torches and Consumables to suit, such as:**

Gas Nozzels, Gas Diffusers, Contact Tip holder, Contact tip, Swan Necks, Trigger, Handle, Liners, Wire Guide, Drive Roller, Gas Nozzle Spring, Neck Spring, Connector Block, Insulator, Gas Nipple, Cap, Euro Block, Head Assembly, Gas Block, Trigger Spring, Spring Cable Support, Neck Insulator, Shroud Spring, Gun Plug Cover, Lock Nut, Snap On Head, Spring Cap, Ball, Motor 42 Volt, Pot 10K standard, Knob, Drive Roll Seat, Washer, Bow, Ball Bearing, Wire Conduite Nipple, Central Plug, Printed Circuit Board, Gun Plug House, Cable Support, Gas Connector, Handle To Suit PP36 with Knobs, All Xcel-Arc/ Magmaweld Mig Welding Wires & Electrodes, Arc Leads, Welding Cable, Electrode Holder, Earth Clamps

## **TIG Welding Torches and Consumables to suit, such as:**

Tungsten Electrodes, Collet, Collet Body, Alumina Nozzle, Torch Head, Torch Head water Cooled, Torch Head Flexible, Back Caps, Gas Lens, Torch Handle, Cup Gasket, Torch Body Gas Valve, O-ring, All UNI-MIG TIG Welding Rods, All Xcel-Arc/ Magmaweld Electrodes, Arc Leads, Welding Cable, Electrode Holder, Earth Clamps.

## **PLASMA Cutting Torches and Consumables to suit, such as:**

All Cutting Tips, All Diffuser/Swirl Ring, All Electrode, Retaining Caps, Nozzle Springs, All Spacers, All Shield Caps, All Air and Power Cables, All Switches, All O-rings, All Springs, All Circle Guides and Cutting Kits, Torch Bodies, Air Filter Regulator, Arc Leads, Welding Cable, Electrode Holder, Earth Clamps

## **STRAIGHT LINE CUTTING MACHINES and Consumables to suit, such as:**

Hoses, Fittings, Track, Cutting Nozzles.

## **HIT-8SS Welding Carriage Consumables to suit, such as:**

Input Cord, Inter-connecting Cord, Triggering Cable.

This Warranty does not cover products purchased:

- From a non-authorized UNI-MIG, UNI-TIG, UNI-PLAS, UNI-FLAME, TECNA, T&R, HIT-8SS & ROTA Dealer (such as purchases from unauthorized retailers and purchases over the Internet from unauthorized local/international sellers or sites such as EBay)
- At an auction;
- From a private seller

Unless it is a manufacturing fault, this Warranty does not apply to any products sold to Hire Companies.

These conditions may only be varied with the written approval of the Directors of Welding Guns Of Australia PTY LTD

**REMEMBER TO RETAIN YOUR ORIGINAL INVOICE FOR PROOF OF PURCHASE.**



MACHINERYHOUSE

MACHINERYHOUSE

MACHINERYHOUSE



*Welding Guns Of Australia Pty Ltd*  
ABN: 14 001 804 422

PO Box 3033, Lansvale NSW 2166, AUSTRALIA  
112 Christina Rd, Villawood, NSW 2163  
Phone: (02) 9780 4200  
Fax: (02) 9780 4244  
Email: [sales@unimig.com.au](mailto:sales@unimig.com.au) / Web: [www.unimig.com.au](http://www.unimig.com.au)